

# Canadian Vintage Modifieds Rules Book 2026



This book covers:

General Rules  
Technical Procedures  
Technical Rules  
Penalties for Rules Infractions  
General Procedures, Points, Race Format and Handicapping  
Staff Duties  
Duties of the Committee and Staff  
Mentor Program

**CANADIAN VINTAGE MODIFIEDS**  
**TABLE OF CONTENTS**

---

## Table of Contents

GENERAL RULES.....	1
Conduct Rules.....	1
Official Decisions.....	2
Election, Voting and Other Procedures.....	2
TECHNICAL PROCEDURES.....	3
1. Make-Up Of Tech. Committee.....	3
2. Duties.....	3
3. At Track Tech. Procedures.....	3
4. General Procedures.....	4
5. Protest.....	4
TECHNICAL RULES 2026.....	5
1. Technical Notes.....	5
2. Eligibility.....	5
3. Club Sponsors.....	5
4. Frame, Roll Cage, Firewalls and Body.....	5
Frame.....	5
Roll Cage.....	6
Firewall and Floor.....	6
Bodies.....	6
5. Weight.....	7
6. Crash Guards and Nerf Bars.....	7
Crash Guards.....	7
Nerf Bars.....	7
7. Steering, Brakes and Starter.....	8
Steering.....	8
Brakes.....	8
Starter.....	8
8. Suspension.....	8
Front Axles.....	8
Springs.....	8
Shocks.....	9
9. Fuel Systems and Fuel.....	9
10. Engine.....	9
11. Carburation, Intake Manifolds and Exhaust.....	12
Carburation.....	12
Intake Manifolds – 6 Cylinder Engines.....	12
Exhaust System.....	12
12. Ignition.....	13
13. Clutch and Transmission.....	13
14. Rear Ends and Driveshaft.....	13
Rear Ends.....	13
Drive Shaft.....	14
15. Tires and Wheels.....	14
16. Cooling System.....	14
17. Mandatory Safety Equipment.....	14
Driver's Compartment.....	14
Seat and Seat Belts.....	14
Driver Equipment.....	15
Radios.....	15
Transponders.....	15
18. Crate Engine Carburetor Claim Rule.....	15
19. Technical Diagrams.....	16
Figure 1: Frame Requirements.....	16
Figure 2: Roll Cage Requirements.....	17
Figure 3: Primary Axle Design.....	18

# CANADIAN VINTAGE MODIFIEDS

## TABLE OF CONTENTS

Figure 4: Alternative Axle Design (V.R.O.A Style) .....	19
Figure 5: Typical Front Crash Guard.....	20
Figure 6: Typical Rear Crash Guard .....	21
Figure 7: Fuel Pump Wiring Schematic.....	22
<b>PENALTIES FOR RULES INFRACTIONS.....</b>	<b>23</b>
1. Cosmetic: .....	23
2. Technical:.....	23
3. Drive Line:.....	23
<b>GENERAL PROCEDURES, POINTS, RACE FORMAT AND HANDICAPPING .....</b>	<b>24</b>
1. General Procedures:.....	24
Sign-in Procedure.....	24
Line-up Procedure.....	24
Scoring and Officiating .....	24
Starts and Restarts.....	24
Race Policies.....	24
Membership and Attendance .....	25
Rookies .....	25
Mechanic's and Powder-Puff Races .....	25
2. Points .....	26
3. Race Format and Handicapping .....	28
Race Format.....	28
Handicapping for First Event.....	28
Handicapping for Regular Events .....	29
Additional Procedures .....	30
<b>DUTIES OF COMMITTEE AND STAFF .....</b>	<b>32</b>
<b>MENTOR PROGRAM.....</b>	<b>35</b>
<b>NOTES.....</b>	<b>36</b>
<b>2026 TECHNICAL BULLETIN .....</b>	<b>38</b>
<b>2026 TECHNICAL BULLETIN SIGN-OFF .....</b>	<b>39</b>
Revision Log.....	39

# CANADIAN VINTAGE MODIFIEDS

## GENERAL RULES

### GENERAL RULES

1. The rules and/or regulations set forth in this book are designed to provide for the orderly conduct of racing events and to establish minimum acceptable requirements for all events. These rules shall govern the condition of all events, and by participating in these events, all participants are deemed to have complied with these rules. They are intended as a guide for the conduct of the sport and are in no way a guarantee against injury or death to any participant, spectator or Official. No expressed or implied warranty of safety shall result from publications of, or compliance of these rules and/or regulations.
2. All persons admitted to the pits and/or restricted areas of a Canadian Vintage Modifieds (C.V.M.) sanctioned event must obey all rules and regulations set forth by the C.V.M. Each person so admitted releases the C.V.M. of all liability.
3. Drivers, car owners, mechanics and crew members shall have no claims against the C.V.M. or its Officials, agents, affiliates or race organizers, by reason of disqualification or damage of either personal injury or property.
4. The C.V.M. reserves the right, in the public image of the sport, to disapprove any advertising or sponsorship.
5. All drivers must have a membership before competing in any C.V.M. event. Drivers must be a minimum of 14 years of age. Any driver under the age of 18 must provide a notarized signed guardian consent form to race with the club.
6. Car numbers will be given out by the treasurer when they receives your membership fee. All previous competitors have their last year's number reserved until the general membership meeting, typically in February.
7. Only members of the Business Committee may negotiate races, purses etc. with promoters. All other members will be subject to discipline.
8. General and Committee meetings will be held regularly year-round, and regular club update will be issued through email, website and/or other sources.
9. New Drivers/Part time Membership: Options 2-night grace with a mechanic's membership or \$100.00. At the discretion of the board, teams may be permitted to race without a paid membership and have the fees deducted from their awarded payout (\$100.00 for two race event, and the remaining balance taken from the third race event).  
Teams without a paid membership will be required to start at the rear for any race (heat or feature) until the fees have been paid in full. Points will not be officially awarded and will be denoted in the posted points with an asterisk until the membership fees have been paid in full. Points will not be adjusted if a membership is not fully paid (i.e. 4<sup>th</sup> being awarded 3<sup>rd</sup> points).
10. C.V.M Board reserves the right to accept or decline any membership to the club for any reason.

### Conduct Rules

1. Participants in C.V.M. sanctioned events are to conduct themselves in an orderly manner not detrimental to auto racing.
2. Verbal and/or physical abuse of any C.V.M. Official agent, representative and/or use of improper language is strictly prohibited. Disorderly behavior at any event will subject offenders to suspension and/or fine, as determined by the Vice President or Committee appointed person. Drivers are responsible for the actions of their crew, and non-members.
3. Alcoholic beverages and/or drugs are prohibited until the completion of the race meet, all divisions, and Tech. Violation or suspicion of violation of this regulation will result in an immediate suspension of the offender(s) from further participation.
4. The conduct of any participant during the course of any event that is deemed unsportsmanlike could be subject to loss of points and/or prize money and/or membership.
5. All persons admitted to the pits and/or or restricted areas of a C.V.M. sanctioned event, car owners and drivers are responsible for all persons associated with their cars and/or crew. Any verbal and/or physical abuse of any C.V.M. Official, Committee Member, Driver or General Member, will be subject to a penalty resulting in receiving only show points and tow money for that race event. Penalties will increase with any additional penalty.

# CANADIAN VINTAGE MODIFIEDS

## GENERAL RULES

---

### **Official Decisions**

1. The C.V.M. reserves the right to determine and interpret the intent of all rules and specifications governing sanctioned events and their decision is final.
2. Any situation not specifically covered herein, will be acted upon by the Race Director and/or the Officials in charge and their decision is final.

### **Election, Voting and Other Procedures**

1. Elections for the Executive Committee to be held at the Annual membership meeting, typically in September.
2. Both nominations and elections to be done at this meeting. Person(s) must be present to accept a nomination. Proxy nominations may be accepted upon request.
3. One vote per car.
4. Elections will be done by written ballot only. Immediately following the count the elected member will be declared. The final count totals will be recorded in the 'Committee Meeting Minutes' and will be made available to the candidates should they wish to review.
5. All alternates are kept on record, in order of votes received, the alternate will be asked to step forward, if needed, without an election held.
6. The New Executive Committee will join the former Executive Committee at the next Committee Meeting where information and authority will be transferred to the New Executive Committee.
  - a. The New Executive Committee will take over at the next general membership meeting, and will oversee the next year's rules and procedure changes.
  - b. The former committee will be responsible for banquet to be held, typically in November.
7. The General Membership Meeting will be a rule/ procedure proposal meeting.
  - a. No voting on technical or procedural changes.
  - b. The Executive Committee was voted to run the club. They will consider all of the proposals and make decisions on any technical or procedural changes which are in the best interest of the club.
8. All meetings must have a sign-in sheet. If you do not attend a general, or specified meeting (rules etc.), you will lose the right to protest anything discussed, or voted on at the meeting.
9. All decisions from meetings (votes, etc.), to be announced to the Membership.

# CANADIAN VINTAGE MODIFIEDS

## TECHNICAL PROCEDURES

---

### TECHNICAL PROCEDURES

#### 1. Make-Up Of Tech. Committee

- Head of Tech. Preferably, a non-driver could be a Committee Member or appointed personnel.
- Two assistants. Preferably both Committee Members.
- Head of Tech will appoint a first assistant (non-driver).
- When Head of Tech. is unavailable at the track, his/her duties will be transferred to the first assistant, and a third Committee Member will fill in.
- Technical Committee will be comprised of three people at all times.

#### 2. Duties

- The Tech. Committee has the power to disqualify any driver without full Committee consent.
- Disqualification's will be discussed between all three Tech. members. The majority decision will prevail.
- The Head of Tech. may seek advice from other Committee Members at his/her discretion, but final decision still rests with the Tech. Committee only.
- The Head of Tech. is the only one to advise a driver of a disqualification. This will be done in the driver's pit, not in the tech. lane.
- The Head of Tech. is the only person who will respond to any technical protest. The protestor(s) will not be revealed.
- The Tech. Committee has the right to disqualify cars from any line-up for a safety violation.
- The Head of Tech. will keep a Tech. Log book on all inspections performed at each race meet. Upon completions of a technical inspection, the driver will be made aware of any offence, issued the appropriate warning, as laid out in the "PENALTIES FOR RULES INFRACTIONS", and then asked to sign the Log. By signing the Logbook, the driver indicates that he/she has been informed of, if applicable, any offense and that some form of warning or penalty has been issued.
- If there are any arguments over performing any requested procedures, the Tech. Committee has the right to have the car scored as the last car in the feature.

#### 3. At Track Tech. Procedures

1. Drivers MAY be shown the "Tech. Sign" when coming off track OR MAY be instructed via the one-way racing radio that they have been designated for inspection for that event.
2. A member of the Tech. Committee (or appointed personnel) is to accompany and remain with cars that go to tech. lane after events.
3. Any car that goes to their pit, instead of directly to tech. lane, will be disqualified.
4. While in tech. lane, only the driver and one crewmember are allowed.
5. No sealing of engines for 6 cylinders. All inspection and tech. procedures to be completed on the day/night of the event.
6. The Tech. Committee will determine how many cars and which cars, will be checked at any one event.
7. The Tech. Committee will determine what is to be checked at any event.
8. Cars will be allowed to be driven in the pits without helmets unless track rules state otherwise. Helmets must be worn on the racing surface including pit lane. You can only remove your helmet on the racing surface when authorized by an Official; this is during red flags, autograph session and receiving trophies.
9. Any car that loses a bumper or nerf bar will be black flagged for that race. No car may race without both bumpers and nerf bars solidly attached.
10. All cars must conform with the tools used and provided by the tech officials, including by not limited to scales (provided by track, may vary), tire gauge, ride height stick, etc.

# CANADIAN VINTAGE MODIFIEDS

## TECHNICAL PROCEDURES

---

### 4. General Procedures

1. All cars must participate in at least one warm-up session per event or go to the back of their respective heat or first feature. At the discretion of the Tech. Committee, a driver can be exempted, due to mechanical problems, but they must report to the Head Tech. to be excused.
2. The driver is responsible for the technical legality of their cars.
3. The Tech. Committee may check any engines that have blown during the race event for legality.
4. All new concepts and ideas must be taken to the Tech. Committee prior to installation on a car. The Tech. Committee's decision is final.
5. All members are encouraged to assist the Tech. Committee by reporting any tech. violations they observe.
6. All cars will have a safety and technical inspection at the beginning of each year and must complete the mandatory pre-tech form.

### 5. Protest

A protest will only be accepted from a driver of a car competing at that race event.

#### Scoring protest

1. The scorer's will determine the final position in all events. Protests regarding finishes must be given, in writing to the Vice President. Protests must be handed in within 15 minutes of the posted finish.

#### Drive line protest

1. The protest must be in writing and exactly specify what is being protested and signed by the protester. The protest, accompanied with \$50.00 cash, must be in hands of the race director or Head of Tech., no later than 5 minutes before the feature goes on the track. Drive line infractions consists of engine, transmission, driveshaft, and rear end assembly. If the car is found illegal, the \$50.00 will be returned to the protester.
2. When a random power train check is made by the Tech. Committee and the car is found legal, the club will pay the car owner \$50.00 (engine only). First tear down by the club, per car, to be at owner's expense.
3. Cars must not be removed from the race track property until 15 minutes after the last race it competed in, unless permission received from the race director and Head of Tech.
4. All protests, issues and resolutions (or reason for decision) must be made public to the Committee, and read out at the next general membership meeting.

# CANADIAN VINTAGE MODIFIEDS

## TECHNICAL RULES 2026

### TECHNICAL RULES 2026

#### 1. Technical Notes

Anything not specifically covered in these rules is not considered legal. Anything that was considered legal in the past is superseded by this book. Any interpretation and intent of these rules will be ruled upon by the Head of Tech and the Technical Committee. Any questions regarding rules contact the Technical committee.

The tech committee does not rule on the safety of the cars; only that the car comply with the rule book as written and voted on by the members.

Self-Declaration Tech Forms, General Safety Affidavit and Release and Waiver of Liability, Assumption of Risk and Indemnity Agreement shall be completed for every car and/or driver (as required) prior to being permitted for competition.

#### 2. Eligibility

Races are open to all models of pre 1948 Canadian and American closed cars. Original style steel bodies. Handmade steel bodies are allowed UPON APPROVAL from Committee. Pickups, Station Wagons, Convertibles and Roadsters are not eligible.

Any car body brand may use any eligible engine, transmission, or suspension combination. All bodies, engines, transmissions, and suspension must be compliant with the current Canadian Vintage Modified Rule Book.

#### 3. Club Sponsors

1. Each car shall have the correct decals for the corporate (title) sponsor and associate sponsors for the current year clearly displayed in the required locations at all times. Associate sponsors decals and corporate (title) sponsor (if required) and from previous seasons shall be removed.
2. Failure to comply with any sponsorship decal regulations will result in the loss of additional nightly and annual winnings.
3. The corporate (title) sponsor logo shall be clearly displayed on the vertical surface at the top of the windshield, or directly above the windshield.
4. C.V.M. club decals shall be clearly displayed at the base of the A-pillar, in-front of the door numbers.
5. Associate sponsor decals shall be clearly displayed below the C.V.M. club decals, at the base of the A-pillar, in-front of the door numbers. Associate sponsor decals shall not be obstructed by wheels or bars (trailing arms, nerf bars, etc.) when viewed from the side. Associate sponsor decals are to be arranged in conformance with the supplemental decal arrangement diagram (based on current associate sponsors). Allowances may be made for differences in body construction. Additional associate sponsor decals may be required throughout the season.

#### 4. Frame, Roll Cage, Firewalls and Body

##### Frame

6. The only legal frame accepted by the Canadian Vintage Modifieds will be the Canadian Vintage Modifieds tube frame. It must exactly follow the specifications as outlined in Figure 1. The frame requirements are as follows:
  - a. Entire frame must be 2" x 3" x 0.100" minimum wall thickness. Rectangular steel tube up to builders' choice, including mandatory cross members, but not optional cross members. 2" x 3" must be upright.
  - b. Frame rail must be straight between front and rear builder's choice areas, as outlined in the drawing on Page 11. Main frame rails may not be pierced, drilled, or otherwise altered for the purpose of reducing weight. The only holes allowed are for component attachment.
  - c. Front and rear builders' choice must be 2" x 3" rectangular steel tube, including cross members.
  - d. Cross members must be full width of frame and added to the end of builders' choice rails.
  - e. Optional second cross member may be manufactured out of any type steel material.
  - f. Builders' choice may be drilled to provide crush zone but no drilling in cross member.

# CANADIAN VINTAGE MODIFIEDS

## TECHNICAL RULES 2026

- g. " X " in between the frame rails must be made of 1.5" minimum (square or round) tubing, 0.090" wall thickness.
  - h. All new cars and any frame repairs undertaken after February 2007, must have a gusset 1/8" x 2" x 2" added to all vertical welds in the frame. See diagram in back of book.
  - i. Due to manufactures thickness tolerances, there will be a 10% undersize allowance in frame and roll cage thickness specifications.
  - j. Electric welding only on frame and roll cage.
7. Minimum ground clearance is 6.5" to bottom of frame rails, including builders choice, measured with the driver out of the car. Note, the cross member is an integral part of the frame and therefore must abide by the 6.5" frame rule. Air pressure adjustments may be permitted to maximum 20 PSI left and 30 PSI right.
8. Maximum chassis offset on all cars to be measured from back of vertical rim bead to surface of frame rail. Difference in measurement from side to side may not exceed 3". Access for measuring must be provided.

### **Roll Cage**

- 1. Minimum roll cage requirements are as per drawings. Refer to Figure 2.
- 2. All bars in roll cage must be minimum 1.750" O.D. and must be 0.090" minimum wall thickness. Three left side door bars must be as per drawing. Three left side horizontal door bars to be bowed outward. Plates in the left side door bars are highly recommended. Right side must have three door bars as per drawing in back of book. Driver's helmet must be below bottom of all roof bars.
- 3. Due to manufactures thickness tolerances, there will be a 10% undersize allowance in frame and roll cage thickness specifications.
- 4. All 90-degree joints in main cage must have gussets. Triangular joints may be exempted at tech committee's discretion. Gussets must be minimum 1 1/2" X 0.090" thick.

### **Firewall and Floor**

- 1. Cowl may be cut back to original hood line. Firewall must be within 15" of rear of engine measured straight back from center of block. Firewall may not extend forward past front edge of front cowl, except for foot box. Firewall must be made of sheet metal, (min. 20-gauge) must completely separate driver from engine compartment. Firewall must extend to the driver's side of body side and be securely fastened.
- 2. Firewalls must be 20-gauge metal and firewalls must completely separate driver from gas tank compartment.
- 3. Floor must be closed in to the sides of the body from front to rear firewalls. May be done by installing sidewall liners up roll bars and across to window frames. Maximum height of the floor, measured above top of transmission, is 6". (20-gauge metal)

### **Bodies**

- 1. The body is to be considered driver's compartment and cab. No chopping of tops.
- 2. Minimum height from ground to highest point of natural body is 56", measured with the driver out of the car. Bodies must not be offset, side-to-side. Bodies must be centered on main frame rails. Maximum 1/2" off center. Body rake measured along body line and or side window opening with frame level. Maximum 6 degrees rake on body.
- 3. All body panels, including roof inserts, must be made of sheet metal and must be minimum 20-gauge thickness.
- 4. Grills allowed, no die cast grills. Nothing in front of radiator except grill and air scoop to move air into the radiator. Air scoop must not extend past front of crash guard and be no wider than outside of frame rail where mounted.
- 5. All cars must be equipped with a metal hood that must be securely fastened. The hood must extend from outer edges of cowl and radiator or air scoop. Hood or air scoop must cover the radiator.
- 6. Hood scoop can be full length of hood. Scoop cannot be any wider than 2" on either side of air cleaner, and cannot be any higher than 1" above air cleaner, measured at back. Scoop must be flat on top with no flaring to direct air over roof hood scoop must not impair driver's vision. (at the discretion of tech)
- 7. Louvers allowed on hood and side panels only, forward of front firewall.

# CANADIAN VINTAGE MODIFIEDS

## TECHNICAL RULES 2026

8. All window openings must appear as per original dimensions.
9. A clear Lexan windshield is compulsory from top to bottom of windshield opening and full width of windshield opening in front of driver. Lexan must be at least 1/8" thick. No side or rear windows to be enclosed with anything, fully or partially.
10. Body sides flat and solidly attached and must extend to bottom of frame rails. Body sides may have extensions/flares maximum 6" high and 5" wide.
11. Body must be minimum 4" in all locations. Front scoop sheet metal must be minimum 3" off the ground.
12. Rear end of body must follow contour of body until it ends. Rear end of body must extend down to meet rear of frame rails. Rear end of body must be completely closed in with sheet metal. Rear deck filler panel must be 90 degrees to the frame rail and must be completely closed in from body to cross member and from body side panel. (No holes)
13. All cars must have access to the trunk area. Trunk lid must open.
14. No air gaps on hood and trunk lid.
15. Dzus fasteners used on hood or trunk lids and fully enclosed hoods must be "butterfly self-ejecting fasteners". No screwdriver type fasteners.
16. No spoilers. No wings. No fenders, outside of body. No air dams.

### 5. Weight

1. Minimum weight of car and driver after any race shall not be less than 2,300 lbs for cars equipped with 6-cylinder engines and not be less than 2,425 lbs for cars equipped with 8-cylinder engines. Left side weight for all cars shall not exceed 57.5% of the total weight with driver in car. No adding fuel before weighing.
2. Ballast weight must be directly and securely attached to main frame rail or major cross member structure, not sub frame, (entirely above bottom of main frame rails). All ballast must be inside of body panels. No lead shot or liquid type ballast permitted. All ballast weights must be painted white with the car number painted in red or black. Any car losing ballast on the track will be disqualified for the remainder of the event.

### 6. Crash Guards and Nerf Bars

#### Crash Guards

1. Crash guards are compulsory front and rear. Front crash guard must be mounted a minimum of 3" ahead of front cross member to provide a crush zone. Must be constructed of pipe or tubing. No sharp corners or rough edges allowed. Refer to Figure 5 and Figure 6 for the typical front and rear crash guard design, respectively.
2. Crash guards overall height must be a minimum of 11" and a maximum of 14" measured from top to bottom. Center must measure 14" to 16" from ground and must have at least one vertical bar. All measurements to be taken at 6-1/2" ride height.
3. Crash guards must be flat across. No bowed crash guards. Top and bottom bars must extend the same distance from the cross member and must be parallel.
4. Front crash guard to be no wider than chassis at front cross member. Exception on longitudinally mounted four leaf spring cars, crash guard may be as wide as outside of spring perch. Maximum distance from center of right kingpin to the front of the front crash guard must not be more than 32". Both front and rear crash guards must be tied in with steel, flat bar or tubing minimum 1" x 1/8", no tin straps or thin rods. Must be mounted solid at each end, rivets are not allowed.
5. Rear crash guards may extend to 1/2 of rear tire width but must be at least width of chassis at rear cross member. All rookie drivers must have at least one bar on rear crash guard painted bright yellow. No other cars to have yellow crash guards.
6. Optional crash guard (NASCAR Modified type) allowed. All dimensions to remain as standard type. No crash guards or nerf bars to be filled in with any typed of panels.

#### Nerf Bars

1. Nerf bars must not extend past outside edges of tires. Compulsory between front and rear wheels. Nerf bars not allowed in front of front wheels.

# CANADIAN VINTAGE MODIFIEDS

## TECHNICAL RULES 2026

### 7. Steering, Brakes and Starter

#### Steering

1. Any regular type steering box may be used but column must be mounted to the left of dash center. No center steering boxes. Rack and pinion is allowed. All steering parts must have 3" ground clearance. Welds on any steering parts must be properly reinforced.
2. Any type of power steering allowed.

#### Brakes

1. Dual brake system is required. Four-wheel brakes must be in good working order at all times. Any type brake system allowed. No power brakes.
2. Brake lines must be visible from master cylinder to caliper.

#### Starter

1. Cars must be equipped with functional starter at beginning of event.

### 8. Suspension

1. Maximum wheelbase is 118"
2. No independent suspension. No twin I-beams.
3. All suspension design approval is at the discretion of the tech committee. No auxiliary suspension of any kind allowed.
4. No on-board driver controlled suspension or weight adjustments allowed.
5. Load bolts and sway bars may be used.
6. No bird cages of any type on rear axle housing.
7. Spring pocket under driver's seat is to be covered by 1/8" plate.

#### Front Axles

1. Axle must be 54-1/2" maximum kingpin-to-kingpin center.
2. Axle must have 4" drop. 1/2" tolerance on drop for adjustment. Drop measured from top of kingpin boss to top of 2" O.D. tubing. Refer to Figure 3 for primary axle design.
3. Tubing for axles must be 2" O.D. with 3/16" or 0.188" wall minimum thickness. Seamless tube recommended. No square tube axles allowed. Must be constructed of steel.
4. Alternative axles must have 1/2" steel plate, min 7/16" grade 5 bolts, 1/4" tether cable. Alternate axle as per diagram in Figure 4.
5. Axle must act as one piece (e.g. front wheels' camber/caster must not change relative to each other under normal operation). Tech may require partial or full disassembly/disconnection of axle from suspension links (trailing arms, springs, etc.) to index and any split assemblies.

#### Springs

1. Coil-over springs and Ford and Chevrolet style leaf springs allowed only.
  - a. Ford Style: Two transverse leaf springs only
  - b. Chevrolet Style: Four longitudinal leaf springs only
2. Cars with leaf spring suspension on both axles must have matching spring selection on both front and rear axle assemblies.
3. All leaf springs will be made of steel. All springs will have standard eyes on both ends (Quarter elliptic not allowed). Bolted on eyes acceptable on end of spring.
4. Ford style leaf springs must be mounted to frame cross members or optional cross tube only, not to the sub frames. Chevrolet style leaf springs must be mounted to cross member or optional second cross member, and must be solid mounts to rear end housing (U-bolts or welded brackets).
5. Adjustable spring shackles allowed. Load adjusting shackle brackets to be approved by the Tech committee.
6. Coil-over Springs
  - a. Maximum of one (1) coil-over per corner. Coil must be mounted over shock.

# CANADIAN VINTAGE MODIFIEDS

## TECHNICAL RULES 2026

- b. Shock rule remains the same as current rule.
  - c. Both front and rear axle assemblies must have matching spring selection side-to-side (i.e. LF and RF have coil-overs; LR and RR have leaf springs). Spring selection may differ between front and rear axle assembly (i.e. Front having leaf springs, rear having coil-overs).
  - d. Coil bind, bump sticks or spring pre-loaders of any type or design are not permitted.
  - e. Thrust bearing kits are permitted.
7. Bump stops of rubber construction, packers and spacers are permitted.
  8. No slider components allowed.

### **Shocks**

1. Only one shock per wheel. Shock must be steel body construction. No re-buildable, no re-valveable, no adjustable, no remote reservoir shocks allowed. Removable hiem ends allowed. Shock must attach to axle and frame directly. Shocks may not be attached with pivoting linkage or lever system.

## **9. Fuel Systems and Fuel**

1. Fuel cell compulsory. All cells must have an approved vent.
2. Cell must be mounted behind rear firewall and inside perimeter of frame rails.
3. Cell must be completely enclosed in a metal container and securely fastened, safely and properly protected.
4. The lowest part of cell must be above the lowest part of the frame rail where mounted or the lowest part of the cell must be above the lowest part of the rear cross member when fuel cell is mounted behind rear axle.
5. Filler spout on fuel cell must be center or left side of car and must have proper cap. Filler spout may be fastened to body. If filler spout is attached to body it must have two flexible joints to allow for body movement.
6. All fuel lines must run under the floor pan of car and be properly secured. Neoprene (synthetic rubber) gas lines are recommended. No copper lines. Fuel lines must be visible from fuel cell to carb
7. Only metal fuel filters allowed.
8. No alcohol, methanol, or nitro methane.

## **10. Engine**

### **6 and 8-Cylinder Engines**

1. Maximum allowable distance down to the center of crankshaft from a line across the top of the frame at the crankshaft bolt is 5".
2. Engine must mount within 2" of center frame to center of crankshaft nose from side rail to side rail.

### **6-Cylinder Engines Only**

1. Only inline six-cylinder overhead valve engines allowed. Cast iron blocks and heads only. Maximum displacement allowed is 256 cubic inches, including clearance and wear.
2. Formula to determine cubic displacements: Bore X Bore X Stroke X 6 X 0.7854.
3. Engine location: Maximum allowable distance for set back of engine is measure from center line of kingpins measured back to the number one spark plug and is 13". Engine must mount within 10 degrees of OEM position. Chrysler to be in OEM position.
4. The only engines allowed are as listed below with their respective crank strokes.

Chev. 230 cu. in.	3.250" stroke	Chev. 250 cu. in.	3.531" stroke
Ford 240 cu. in.	3.180" stroke	Ford 250 cu. in.	3.910" stroke
AMC 232 cu. in.	3.500" stroke	AMC 243 cu. in.	3.410" stroke
Chry. 225 cu. in.	4.125" stroke		

# CANADIAN VINTAGE MODIFIEDS

## TECHNICAL RULES 2026

5. Only production crankshafts for make and model of engine being used are allowed. No aftermarket crankshafts at all, no custom forged or billet crankshafts. Only original stroke allowed as listed above, no stroke changes at all. All stroke dimensions must be + or - .015" tolerance.
6. Oversized valves allowed. **2 valves per cylinder only (12 total)**
7. An additional allowance of .005" is allowed to provide for manufacturers production tolerance.
8. Any type pistons allowed.
9. Any camshaft allowed. No overhead cams.
10. No oil coolers. No dry sump systems. No external drive oil pumps allowed. A remote oil filter is allowed. Approved pressurized serge tank is allowed (Moroso style) must be securely mounted.

### Alternative 6-Cylinder Large Displacement Engines

*Note: The intent is to have parity between the existing rules regulating the 6-cylinder and 8-cylinder engines. All future 'balance of performance' measures to be determined by the Canadian Vintage Modifieds Board of Directors, and may be implemented immediately throughout the season with notice issued as a Technical Bulletin. Current rules do not guarantee future compliance. Any team developing an engine conforming to the rules below accept any associated monetary or competitive risks.*

1. All 6-cylinder engine will be assumed to conform to rules, with a maximum 256 cu. in, unless tech. has been explicitly notified. Large displacement 6-Cylinder engine alternatives are to conform with all existing rules regulating the 6-cylinder engines, unless explicitly outlined below.
2. The only alternative engines allowed are as listed below with their respective crank strokes.

<b>Chev. 292 cu. in.</b>	4.120" stroke	<b>Ford 300 cu. in.</b>	3.980" stroke
--------------------------	---------------	-------------------------	---------------

3. Maximum displacement allowed is 310 cubic inches, including clearance and wear.

### 8-Cylinder Engines Only

1. The only 8-cylinder engine allowed is the GM 602 Crate Engine Part Number 88958602 (old) or Part Number 19258602 (new).
2. Engines may be rebuilt and resealed by the authorized engine builders listed below:  
\*Note: The authorized engine builders (and any reference to engine builder, rebuilder, etc.) refers to the companies that are authorized to seal an engine for CVM competition. It is encouraged that car owners review the condition of any engine that requires sealing with the authorized engine builder of choice prior to completing any work.

Klotz Auto Repair & Engine Machine Shop  
330 Dundas St S, Cambridge  
(519) 620-4664  
<http://www.klotzautorepair.ca>

DSE Performance  
265 Argyle St N, Caledonia  
(905) 765-8880  
<https://www.dseperformance.com>

3. All crate engines are to have a CVM ORANGE seal (reseal) or Oshweken RED seal (purchased new). Any unsealed engine must be sealed before the engine will be allowed to compete. Any Klotz RED seal engines will be allowed for competition in 2026.
  - a. New GM 602 Crate Engines may be purchased from Oshweken Speedway. Engine must be sealed by Oshweken Speedway prior to taking ownership. Used GM 602 Crate Engines (Non sprint car engines) with seals intact and inspected by Oshweken Speedway will be allowed.
  - b. Any other GM 602 Crate Engines, new or used, MUST be sent to an authorized engine builder to be inspected and sealed before the car will be permitted to race with that engine. This includes unsealed engines that have previously run in the club.
  - c. Second-hand crate engines from outside the Canadian Vintage Modified club are permitted and must meet all engine requirements outlined in the Canadian Vintage Modified club rulebook.
  - d. Removal of any seal (accidental or intentional) will require the engine to be resealed.
4. Engines may be rebuilt at the discretion of the authorized engine builder. Engine rebuild rules are to be in conformance with original GM tolerances (outlined in *GM Performance Parts Circle Track Crate Engine Technical Manual – P/N 88958668*), unless otherwise specified. All parts must be GM OEM parts (or OE equivalent) specific to the 602 crate engine, unless otherwise specified. Parts may be compared to OEM parts for reference where specifications are unavailable. Supplemental rules are specifications are included below:

# CANADIAN VINTAGE MODIFIEDS

## TECHNICAL RULES 2026

- a. General maintenance and component replacement may be completed at the discretion of and by the approved engine builder during the sealing process. All future maintenance and replacement require new seals. Oil pump must be OEM or Melling M55, M55HV or M155HV. Timing chain must be OEM, Cloyes CK-3001 or CL09-3100.
  - b. The approved engine builder may not disclose the list of inspected parts and outlined tolerances. Identifying marks may be scribed as necessary during the sealing process.
  - c. All engine serial numbers, seal numbers and recorded measurements will be documented and catalogued for future reference.
  - d. The approved engine rebuilder reserves the right to refuse sealing an engine if it is believed to be not in conformance. The engine serial number will be recorded, and that engine may not be allowed to race in the club. The owner is responsible to pay all fees.
  - e. Engine blocks may have cylinders bored 0.030" maximum over OEM tolerances. Engine block may be decked 0.010" maximum. Engine blocks may be resleeved at the builder's discretion.
  - f. GM cylinder heads (Part Number 10239906 or 12558062) are required. Alternative cylinder head CCCN Montreal 906S is allowed. Cylinder head milling 0.010" maximum, combustion chamber with 61CC minimum. No grinding of intake and exhaust ports. Compression whistle test to 9.5:1 maximum. Only basic 3 angle valve job permitted.
  - g. Crank shafts (Part Number 10243880 or 14082586) are required.
  - h. Crank shaft rod bearing journals may be concentrically ground to a maximum 0.020" under OEM tolerance. Any offset grinds are strictly prohibited. Crank shafts may be re-balanced.
  - i. Connecting rods must be OEM, OE equivalent (Press fit pin, sintered, standard bearing OD) or Enginetech (ECR304). Minimum weight is 600g ± 10g. Connecting rod bearings must be OEM or OE equivalent.
  - j. Camshaft must be OEM or Sealed Power (ODCC 24502376)
  - k. Replacement flat-top pistons are allowed, up to 0.030" over OEM tolerance. ODCC engraved Sealed Power (ODCC H815DCP 0.020" and 0.030") pistons allowed. Wrist pin height to meet OEM tolerance. Pistons to weigh 470g ± 5g.
  - l. Piston wrist pin to weigh 105g ± 2g.
  - m. Piston rings must be OEM or OE equivalent. No gapless piston rings.
  - n. OEM or PAC Racing Springs (PAC-1210X-16) valve springs allowed. Alternative aftermarket valve springs are prohibited. Valve springs may be shimmed 0.020" maximum. Valve spring to weigh 66g ± 4g.
  - o. Valves must weigh 111g ± 4g intake and 94g ± 4g exhaust.
  - p. Main crank shaft bearings must be OEM or OE equivalent.
  - q. Cam shaft bearings must be OEM or OE equivalent.
  - r. Lifters must be OEM or Sealed Power (HT-817).
  - s. Oil pans to be to be GM Performance (Part Number 2553453). Alternative oil pans: GM Performance (Part Number 2553454) 7", 8 qt. or Champ Pans (Part Number CP106LTRB) 6-1/2", 7qt. magnetic steel oil pan with louvered windage tray.
  - t. Any unsealed component or cover may be removed for inspection at the discretion of the tech director.
5. Balancer to be as it comes from GM. 8 Inch.
  6. Engine location to be 39" max from the center line of front axle to the back of the block where the bell housing mounts.

# CANADIAN VINTAGE MODIFIEDS

## TECHNICAL RULES 2026

### 11. Carburation, Intake Manifolds and Exhaust

#### Carburation

##### **6 and 8-Cylinder Engines**

1. Maximum 18" diameter air filter allowed.
2. All carburetors must have two throttle return springs. All cars must be equipped with an intake air filter or flame arrestor.
3. No supercharging, turbocharging or injecting devices allowed.
4. No fuel pumps with glass bowls allowed.

##### **6-Cylinder Engines Only**

1. Any Holley two-barrel carburetor allowed, except part #s:0-80600, 0-80585 and 0-80590.
2. No cutting or welding other than maintenance on intake manifold.
3. Electric fuel pumps allowed. Must run wiring configuration as per diagram in Figure 7.

##### **8-Cylinder Engines Only**

1. STOCK Holley 500 cfm model #'s 0-4412C and 0-4412CT. NO Modifications allowed accept removal of choke plate and related linkage. MUST use STOCK metering block Part #134-137 with stamped #5925-3
2. Any new or revised manufacturer part number must be brought to the immediate attention of the Tech Director who will verify part numbers with Holley Performance.
3. Jets, accelerator pump, power valve and vent tube may be changed.
4. No HLY-4412HP Carburetors allowed.
5. Only one aluminum carburetor adapter must be used, PN 90027 by Reliance Precision or PN Super Sucker SS4412-2AL by High Velocity Heads.

#### Intake Manifolds – 6 Cylinder Engines

1. Original equipment intakes allowed. No altering corners of intake, no cutting or welding on intakes other than for maintenance. Carburetor adapter must mount to original mounting surface and use original bolt holes of intake manifold for engine being used.
2. Clifford manifolds allowed. Outside cosmetic altering permitted, original part numbers must remain. Absolutely no welding or cutting permitted. No internal modifications permitted on manifold other than to clean up along the line where the two halves are joined  $\pm\frac{1}{4}$  inch max tolerance. Anything else must be approved by tech before it is modified.
3. The maximum diameter of the carburetor adapter is not to exceed 1.760" wide, 3.500" long, with a true circle radius at both ends and be at 90 degrees from the upper and lower face. No tapering of opening.

Chevrolet	# C-4501	Ford	# F-4502
AMC 1987-90	# 4510	AMC 1990+	# 4520
Adapter	#08-1013 (casting # A-0452)		

#### Exhaust System

##### **6 and 8-Cylinder Engines**

1. Left side exhaust pipes must extend past 'A' post of body and be turned away from driver's compartment
2. Top of any outlet must not be more than 18" from ground.
3. Mufflers mandatory. May run any muffler system equivalent to the Magnaflow.

##### **6-Cylinder Engines Only**

1. Header Plate (6-cylinder engines only):
  - a. Header/intake plate may be used, maximum thickness 1/2"

##### **8-Cylinder Engines Only**

1. Headers are allowed, No – 180 Degree ("CROSSOVER ") or Tri-y style ("IRON LUNG") headers allowed (8-cylinder engines only).

# CANADIAN VINTAGE MODIFIEDS

## TECHNICAL RULES 2026

### 12. Ignition

#### 6 and 8-Cylinder Engines

1. Battery must be securely fastened in engine or trunk compartment only. Battery cables must be properly secured.
2. Ignition kill switch must be mounted in accessible area to driver and safety crew and must be clearly marked. Off must be in or down.
3. No on-board driver adjustable electronic controls.

#### 6-Cylinder Engines Only

1. Any ignition system allowed except Magneto's.

#### Alternative 6-Cylinder Large Displacement Engines

1. MSD 8728 Rev. Limiter Box with a MAX. 6500 Rev. Limiting Chip must be used.
  - a. All wires for the Rev. Limiter Box must be left exposed for tracing purposes.
  - b. Rev. Limiter Box must out of the reach of the driver.
  - c. Rev. Limiter Box must be mounted with the Rev Limiter chip facing away from the driver.

#### 8-Cylinder Engines Only

1. Only Stock Distributors can be used (no alterations), must run the distributor supplied with the motor.
2. No MSD, DUI, Accel or other performance aftermarket ignition modules.
3. Distributor mechanical and vacuum advance system lock-out permitted: Champ Pans CP725 and CP726, and Proform PRO-67022C.
4. MSD 8728 Rev. Limiter Box with a MAX. 6200 Rev. Limiting Chip must be used.
  - d. All wires for the Rev. Limiter Box must be left exposed for tracing purposes.
  - e. Rev. Limiter Box must out of the reach of the driver.
  - f. Rev. Limiter Box must be mounted with the Rev Limiter chip facing away from the driver.
5. Distributor cap may be removed for inspection of module, mechanical advance and coil.

### 13. Clutch and Transmission

#### 6 and 8-Cylinder Engines

1. Three speed OEM transmission only. Any make in any car. Reverse and all forward gears must work. No automatic transmissions. No quick change transmissions or transmissions with internal clutch. No overdrive units. No in and out boxes. No 4 or 5 speed transmissions allowed.
2. Clutch must work and be foot operated. Multiple disc or aftermarket mini single disc clutch allowed. Minimum 7 ¼" disc size. No couplers.
3. Stock flywheels allowed. Aluminum flywheels allowed. Automatic transmission flex plates allowed.
4. Commercial aftermarket steel blowout proof bell housing compulsory. Must be left as manufactured. No cutting, except for right hand clutch fork, left side clutch fork hole must be covered also lower lip can be removed. Aluminum bell housing allowed with use of 7.25" clutch only.

### 14. Rear Ends and Driveshaft

#### Rear Ends

1. OEM and quick-change rear end allowed in any car.
2. Aluminum spools and pinion bearing support bearings allowed. Rear ends must be locked. No OEM posi-traction units. No rear-ends with any type of unlocking or unloading devices. No electronic traction control devices allowed. Axle tubes and axle shafts must be constructed of magnetic steel.

#### OEM Rear End

1. No integral style rear ends with internal axle locks allowed. No aftermarket center sections or aluminum pots.

# CANADIAN VINTAGE MODIFIEDS

## TECHNICAL RULES 2026

### Quick-Change Rear End

1. 10" ring gear.
2. No cambered rear ends.

### Drive Shaft

1. All driveshafts must be constructed of steel. No constant velocity joints of any type. All driveshafts must be painted bright white with the car number identified.
2. All cars must be equipped with a full 360-degree driveshaft loop front and rear. Loops must be made of 3/16" x 1-1/2" plate or equivalent. The front loop will be 3" to 6" behind front u-joint. The rear loop will be 3" to 8" before the rear u-joint.

## 15. Tires and Wheels

1. All cars must use 5 lug wheels only. No uni-lug wheels.
2. All four wheels must be approved commercially manufactured steel wheels. No OEM wheels.
3. Minimum offset to wheel center from inner edge of wheel is 2".
4. Maximum width for all wheels is 8".
5. Tires must be used as per tender specifications approved by the membership. All tires must be within a durometer reading as determined by Tech.
6. NO tire soaking allowed.

## 16. Cooling System

1. Any type radiator may be used providing it is not higher than hood or wider than frame. Hood or air scoop must completely cover top of radiator
2. Radiator must be fastened at front of car. No auxiliary cooling cores.
3. No antifreeze in cooling system.
4. Cars must have a catch or over flow can of not less than 2 liter capacity and this must be drained prior to each race. Can must be located forward of front firewall and cannot be vented anywhere behind front firewall. It is mandatory that you run a hose to the front windshield from the catch can.

## 17. Mandatory Safety Equipment

**(Note: All safety equipment must be maintained at the discretion of the driver/team and must follow manufacturers recommendation. Any equipment that does not conform must be replaced.)**

### Driver's Compartment

1. Fire extinguishers are mandatory. Minimum 2-1/2 lbs. must be mounted safely. Must have a gauge. Must be within drivers reach. Halon onboard systems accepted. If extinguisher gauge is empty or reads out of green zone, car will not be permitted to run.
2. All bars in the driver's compartment must be covered with fire retardant padding. If running door liner on left side, sheet padding is recommended. Center of steering wheel must be completely padded. Lexan steering wheel cone inserts recommended.
3. Driver's compartment to be void of all sharp or unprotected objects and surfaces.
4. Drivers window nets are recommended. Must hook at top and release at front.

### Seat and Seat Belts

#### Seat

1. An aluminum racing seat (0.125" thickness) must be securely fastened to the cage or frame at bottom and backrest. Seat must have a padded headrest. Seat must be mounted above 2" X 3" frame rail. Full containment seat recommended.
2. A Full Containment seat is recommended.

#### Seat Belts

1. Seat belts must be current within one month of the manufacturer's stated expiry date. Failure to comply will result in winnings from the current event being withheld.

# CANADIAN VINTAGE MODIFIEDS

## TECHNICAL RULES 2026

2. 3" wide made-for-racing seat belts with double shoulder harnesses must be used. They must have a quick release and must be fastened to structural members with grade 8 bolts and locknuts. Crotch strap recommended.
3. 2" wide shoulder belts allowed when used in conjunction with appropriate head and neck restraint devices

### Driver Equipment

1. Driver must have a helmet that is no more than 10 years old as indicated by the Snell Foundation certification sticker (SA Rated). Helmets will be inspected and must have sticker. It is recommended that drivers record blood type and RH factor plus any major medical allergies to adhesive type label on inside of helmet. It is also recommended that drivers remove dentures while competing.
2. S.F.I. approved (SEMA Foundation Inc.) P.B.I. or Nomex designed-for-racing for suits are mandatory. No Proband fire suits. Suits must be in good shape and clean. Fireproof underwear, socks and helmet sock are highly recommended.
3. Fireproof racing gloves and racing shoes/boots are mandatory.
4. A head and neck restraint system is recommended.

### Radios

1. Any 2-way radio system may be used. Two-way radios are to be used for safety purposes only. Drivers may lose the right to use two-way radios if erratic or dangerous maneuvers are witnesses.
2. Drivers who choose to use a two-way radio will be required to disclose their channel frequency, including secondary channels.
3. One-way radio to Track Officials MANDATORY. One-way radio must be with driver, compatible with 2-way radios if required (i.e. Raceceiver Legend+). One-way radio traffic from the race official MUST take priority over any other radio traffic.
4. One-way radios are considered to be part of safety equipment, cars cannot race without one.
5. One-way radio to be used with track officials only for lineups, scoring and penalties.
6. Failure to conform to commands from the race director over the one-way radio may result in loss of starting position or restart position.

### Transponders

1. Transponders are MANDATORY.
2. Transponder must be located a minimum of 79" from the center of the front axle.

## **18. Crate Engine Carburetor Claim Rule**

1. An issue of claim may be made by a car owner/driver against a fellow competitor engine carburetor that is competing prior to the start of the event.
2. The claim must be made in writing to the Committee/Tech Committee prior to the start of the feature.
3. The claimant must present a NEW replacement carburetor to be exchanged on the same night with receipt.
4. Claim rule applies to the carburetor as provided from the manufactures. Removal of jets, power valve, and throttle cam will be allowed prior to the exchange, in front of the Head of Tech.
5. Exchange must be made on the night of the claim.
6. If claim if refused, car that refused will be deemed to have an illegal carburetor and will be penalized as per rules.

# CANADIAN VINTAGE MODIFIEDS TECHNICAL RULES 2026

## 19. Technical Diagrams

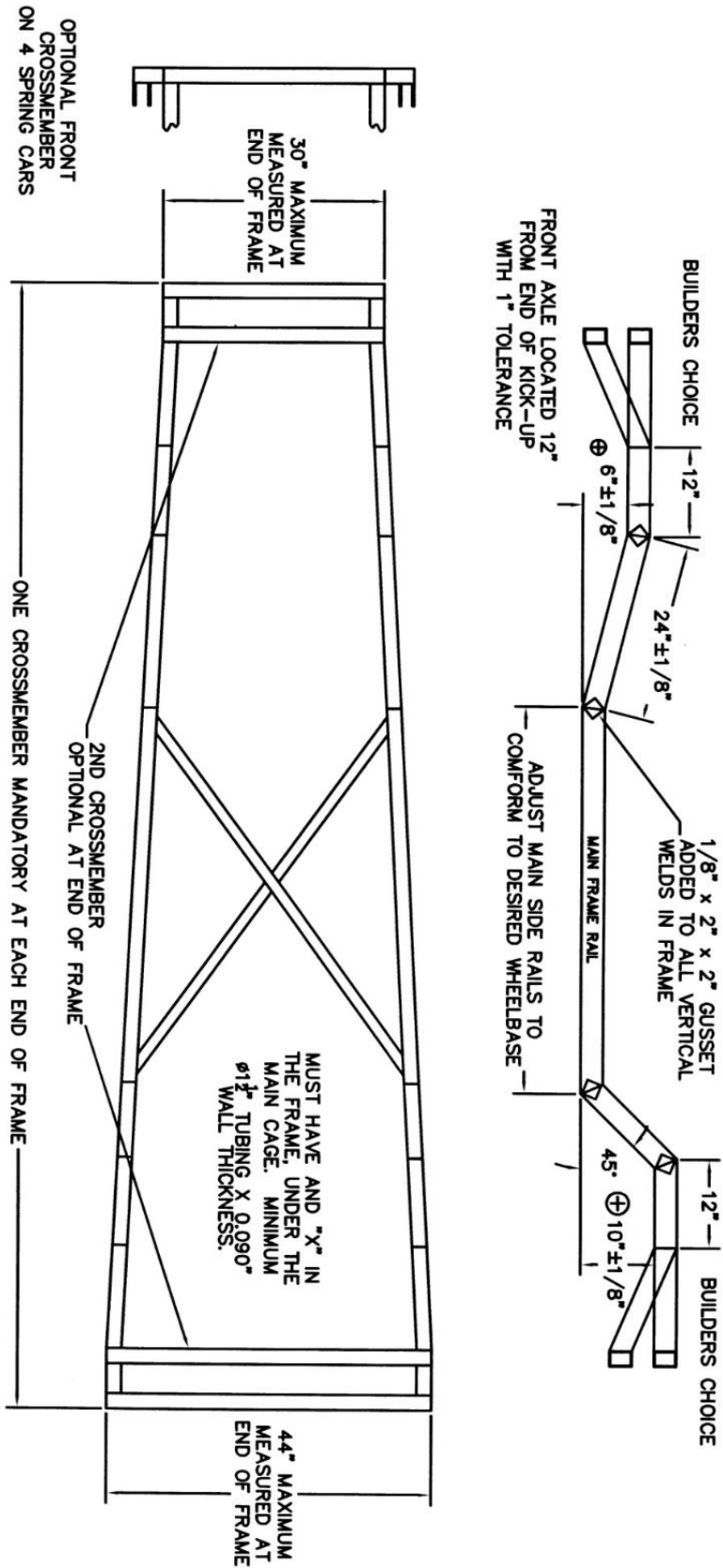

**Figure 1: Frame Requirements**

**ENTIRE FRAME MUST BE 2" x 3" x 0.100" WALL THICKNESS**  
There will be a 10% undersize allowance for frame and roll cages.

# CANADIAN VINTAGE MODIFIEDS TECHNICAL RULES 2026

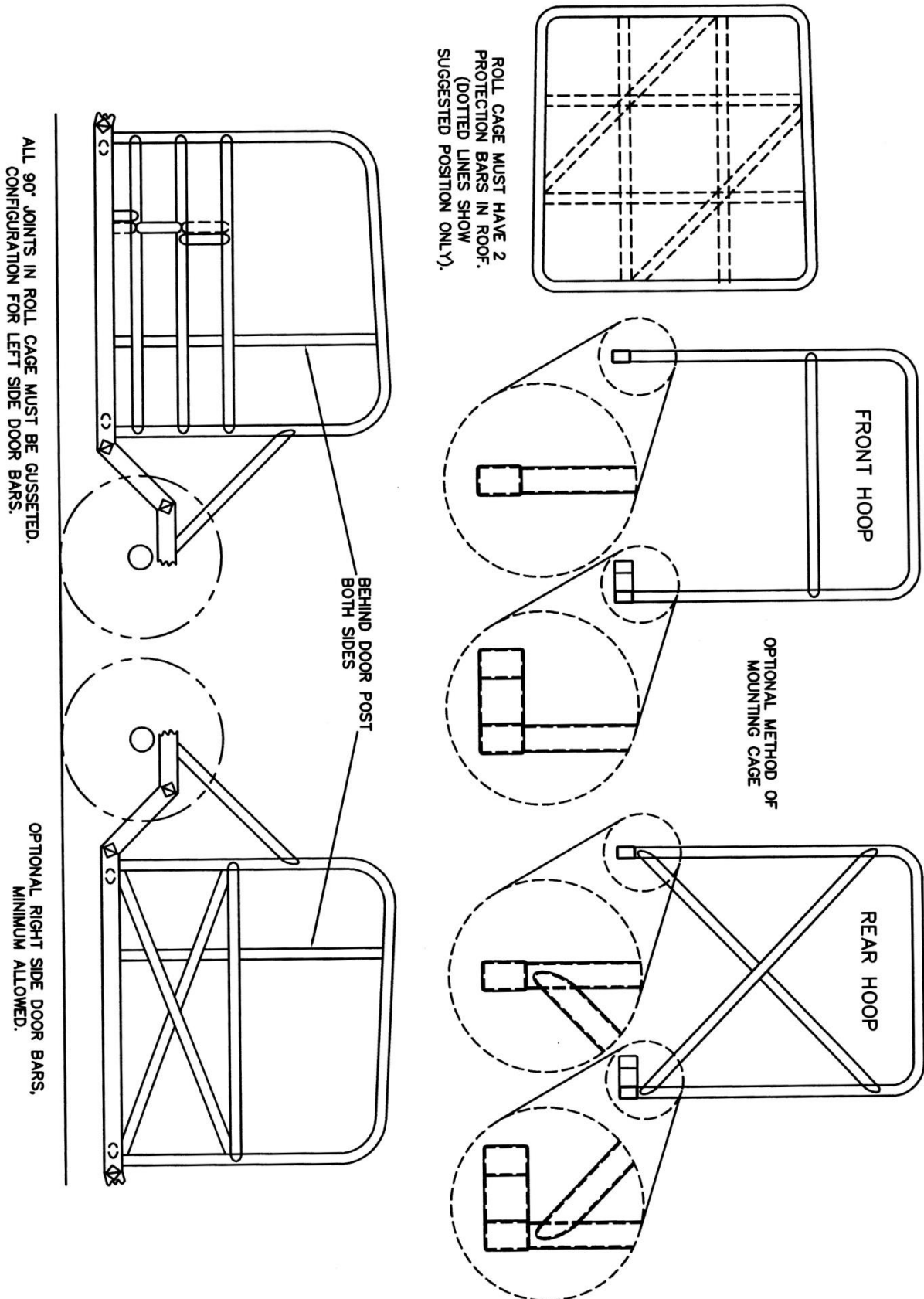

**Figure 2: Roll Cage Requirements**

# CANADIAN VINTAGE MODIFIEDS TECHNICAL RULES 2026

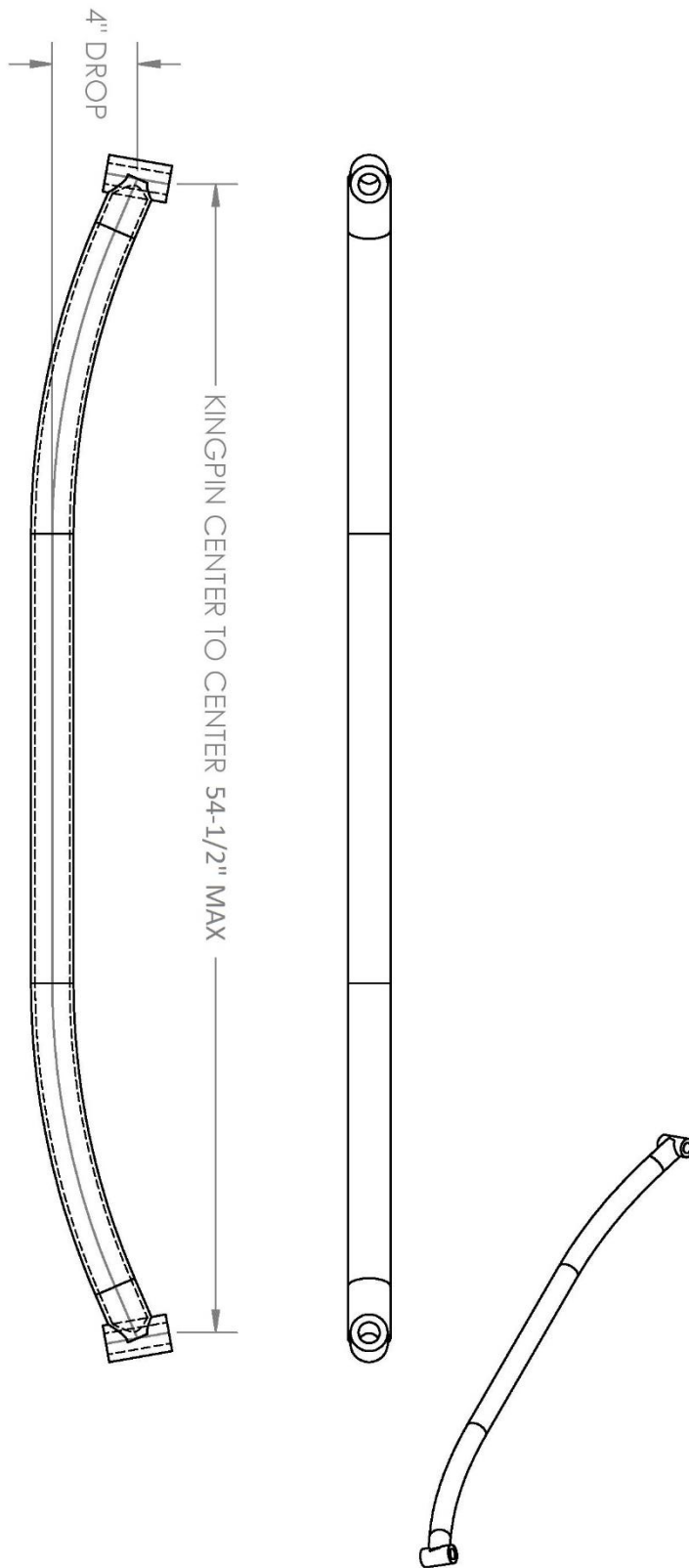

**Figure 3: Primary Axle Design**

MUST BE CONSTRUCTED OF 2" O.D. STEEL TUBE WITH 3/16" OR 0.188" MIN WALL THICKNESS  
SPINDLE BOSSES MUST BE WELDED TO END OF TUBE

# CANADIAN VINTAGE MODIFIEDS TECHNICAL RULES 2026

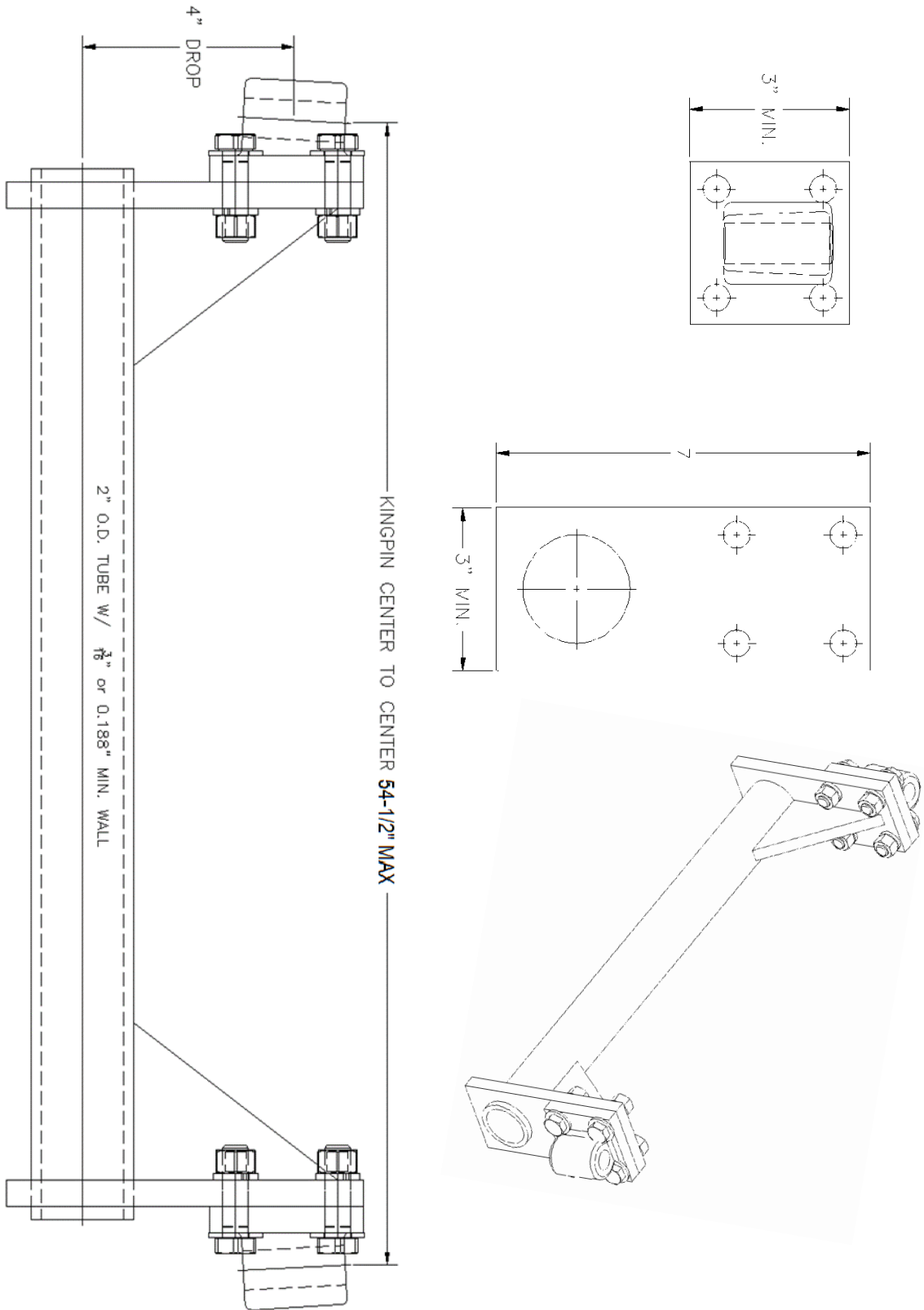
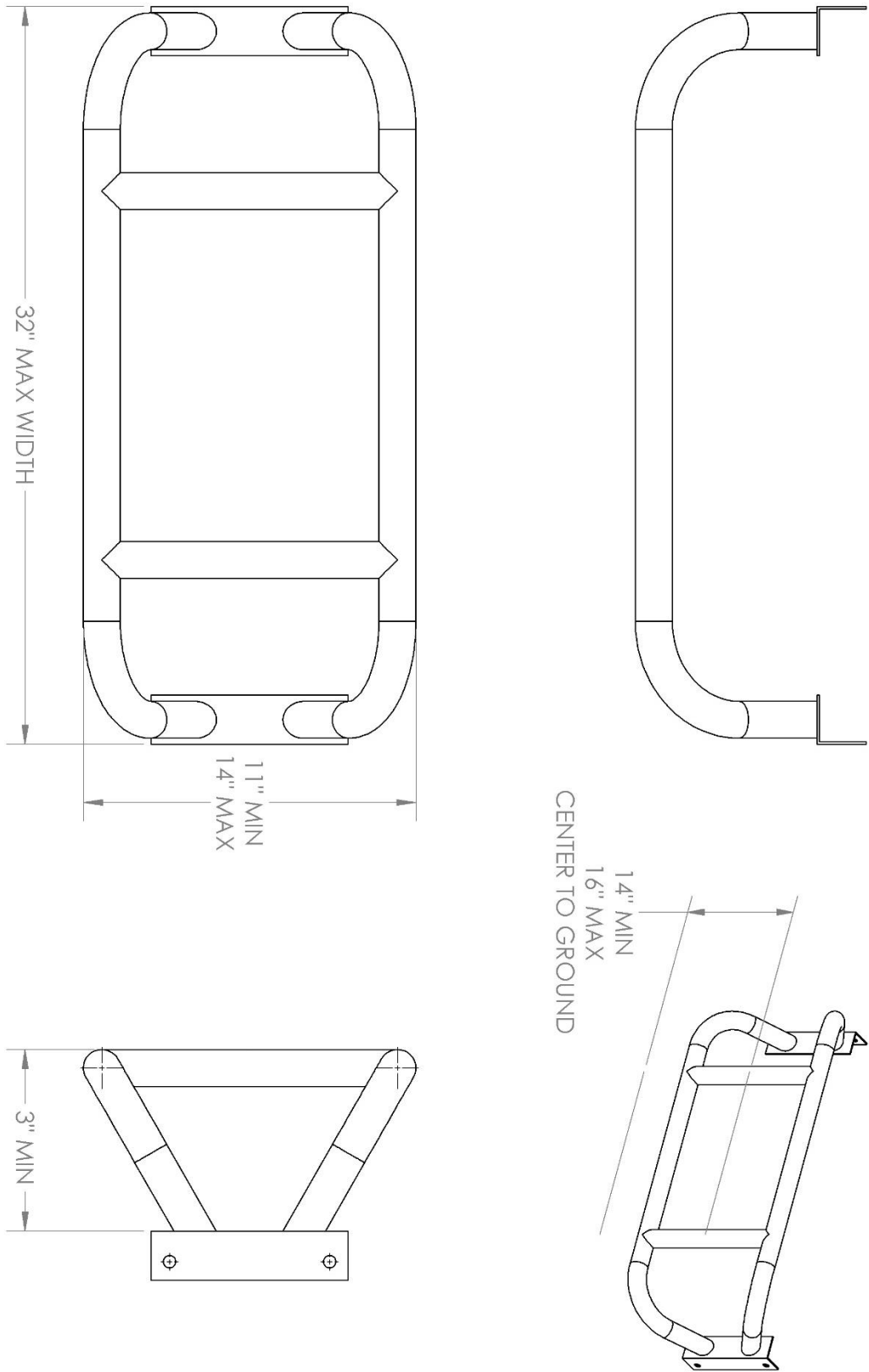

**Figure 4: Alternative Axle Design (V.R.O.A Style)**

MUST BE CONSTRUCTED OF STEEL, 1/2" STEEL PLATE, MIN 7/16" GRADE 5 BOLTS, Ø1/4" TETHER CABLE.

**CANADIAN VINTAGE MODIFIEDS  
TECHNICAL RULES 2026**

**Figure 5: Typical Front Crash Guard**



FRONT CRASH GUARD TO BE MINIMUM 3" FROM FRONT CROSS MEMBER  
 MAXIMUM WIDTH BASED ON FRONT FRAME RAIL (32" MAXIMUM)  
 MINIMUM 1 VERTICAL MEMBER  
 ALL MEASUREMENTS TO BE TAKEN AT 6-1/2" RIDE HEIGHT

**CANADIAN VINTAGE MODIFIEDS  
TECHNICAL RULES 2026**

**Figure 6: Typical Rear Crash Guard**

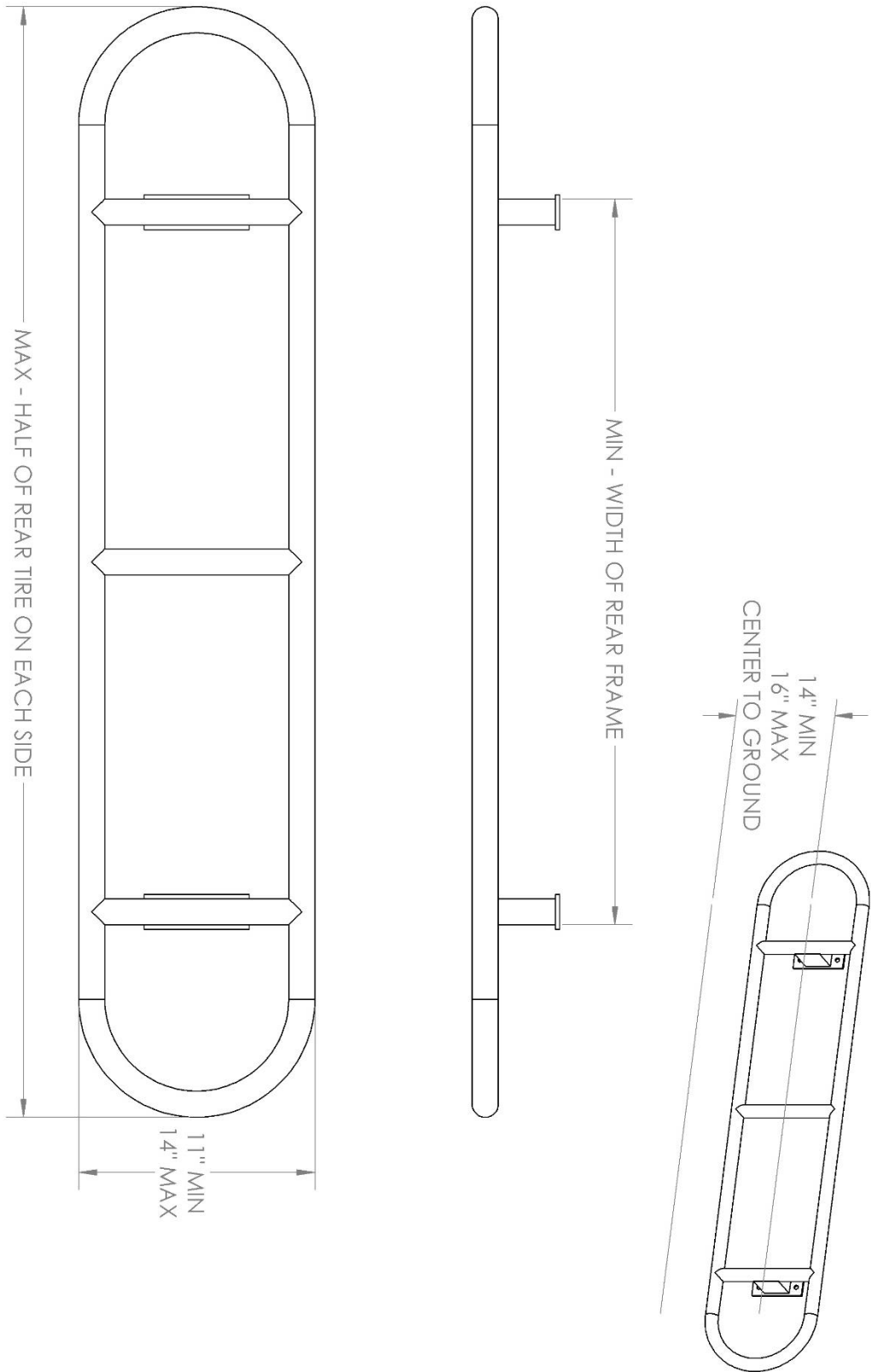

REAR CRASH GUARD TO BE MINIMUM WIDTH OF REAR CROSS MEMBER  
 MAXIMUM WIDTH BASED ON CENTERLINE OF REAR TIRES  
 MINIMUM 1 VERTICAL MEMBER  
 ALL MEASUREMENTS TO BE TAKEN AT 6-1/2" RIDE HEIGHT

**CANADIAN VINTAGE MODIFIEDS  
TECHNICAL RULES 2026**

**Figure 7: Fuel Pump Wiring Schematic**

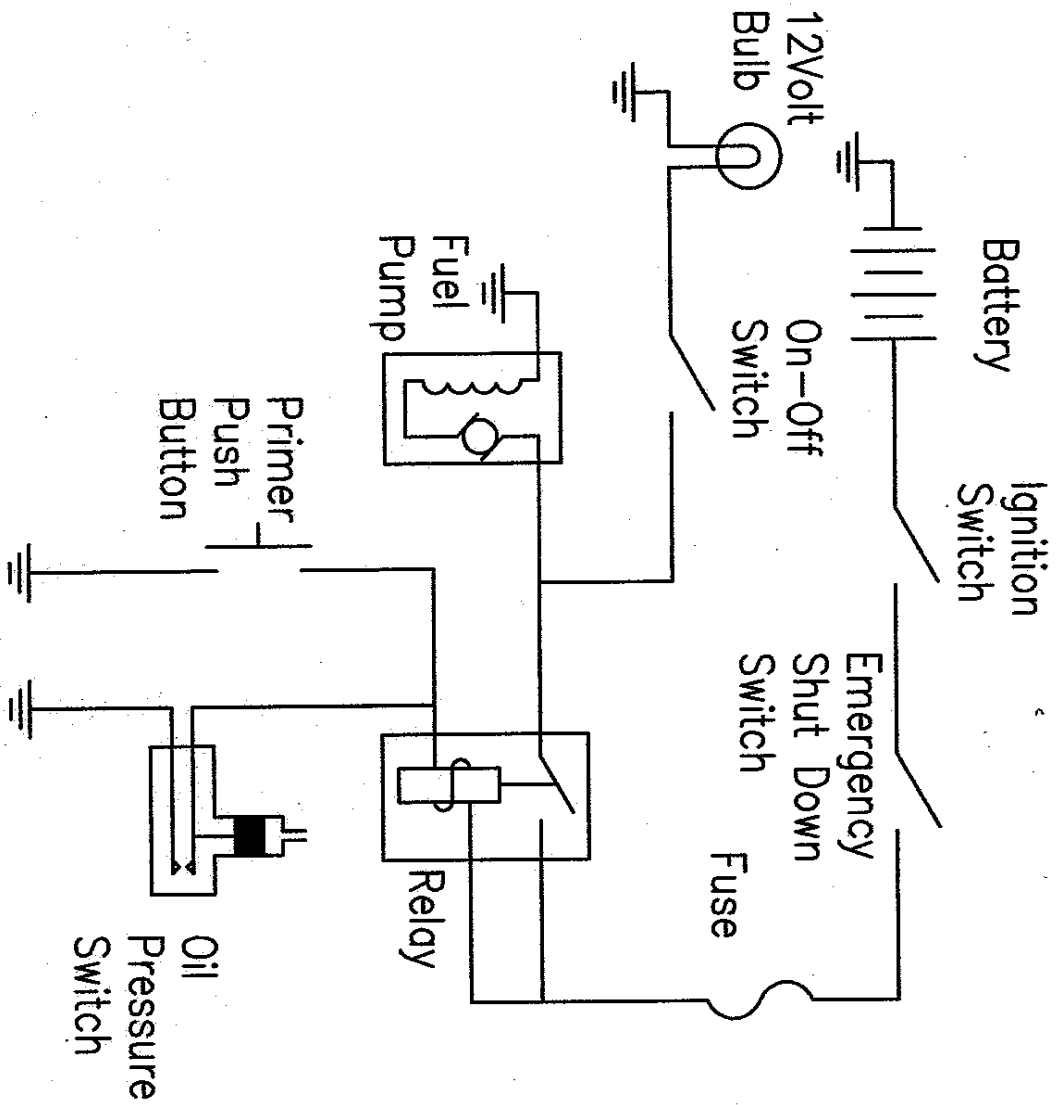

Fuel pump must be mounted on the back of the rear firewall, ABOVE the floor line, on the inside of the frame rail, MINIMUM 6 inches from drive shaft tunnel and on the opposite side of the battery location (if the battery is mounted in the rear).

Car with electric fuel pumps must have its operation inspected on initial yearly check and ANY time it goes through post-race tech inspection. Failure to pass will result in DQ (disqualification). Failure to pass will result in DQ (disqualification).

# CANADIAN VINTAGE MODIFIEDS

## PENALTIES FOR RULE INFRACTIONS

### PENALTIES FOR RULES INFRACTIONS

After safety and technical inspection sheet has been given to the car owner/driver during the one week period of repair allowed, the Tech. Committee will not penalize the driver/car for the noted deviance. Please note that cars must have a hood and truck lid on at all times, and must have side nerf bars on at the start of each race or the car will not be allowed to race. The Tech. Committee, Race Personnel, Track Staff may determine that any car is unsafe to continue, before or during a race. <sup>1</sup>

#### 1. Cosmetic:

- Paint
- Hood Scoop
- Side Panels
- Crash Guards
- Windshield
- Trunk
- Nerf Bars
- Radiator Scoop
- Body Offset (1/2" off)
- Hood
- Anything Appearance Related

The 1<sup>st</sup> time you will be warned, and checked and approved by the Head of Tech. prior to competing in the next Race event.

A 2<sup>nd</sup> infraction for the same infraction will result in an automatic disqualification with only show points awarded and tow money awarded for that event.

A 3<sup>rd</sup> infraction of the same rule, will result in only show points awarded and tow money awarded for that event, and handicapped as feature winner.

A 4<sup>th</sup> infraction of the same rule would result in the loss of all points, monies for the night, as well as 100%, and handicapped as feature winner.

A 5<sup>th</sup> infraction of the same rule, would result in the loss of all points, monies, etc., and a two week suspension. During the suspension period car/driver would be handicapped as the feature winner.

Any further infractions would result in addition to the above, double suspension time, with loss points etc., and handicapped accordingly

#### 2. Technical:

- Rims
- Body Offset (over 1/2")
- Suspension
- Engine Locations
- Chassis Height
- Anti-freeze
- Weight
- Wheel Base
- Chassis Width
- Front Axle Dimensions
- Overall Heights

The 1<sup>st</sup> infraction you will be scored as the last starting car in the feature, money and points for last, handicapped for actual finish.

A 2<sup>nd</sup> infraction of the same rule would result in the loss of all points, monies, etc. for the night, and a two week suspension. During the suspension period the car/driver would be handicapped as feature winners.

#### 3. Drive Line:

- Tires
- Transmission
- Mufflers & Exhaust
- Intake & Carburetor
- Clutch
- Engine Cube
- Lifters
- Suspension (major)
- Drive Shaft
- Head / Valves
- Ignition
- Fuel
- Rear End
- Header Plate
- Main Body Alterations

The 1<sup>st</sup> infraction in any of these areas would result in loss of that night, plus 2 additional nights. No show points or tow money, loss of 100% attendance, handicapped as feature winner.

The 2<sup>nd</sup> infraction, of the same or different offence, that night plus up to one calendar year.

**NOTE: If any car fails to or refuses to complete tech., (i.e. the car leaves the tech. area), the car will be penalized the same as a 1st offense of the drive line infraction, regardless of what remains to be inspected.**

<sup>1</sup> Submitted originally by Penalty Committee Meeting, January 23, 2000. Modified May 6, 2006

**CANADIAN VINTAGE MODIFIEDS**  
**GENERAL PROCEDURES, POINTS, RACE FORMAT AND HANDICAPPING**

---

**GENERAL PROCEDURES, POINTS, RACE FORMAT AND HANDICAPPING**

**1. General Procedures:**

**Sign-in Procedure**

All drivers must sign-in their cars, before going on the racetrack. If you do not sign-in your car, you will not be in the line-up or receive show points or tow money.

Only the driver is to sign-in, and their car must be in the pits when they do so. Any driver that does not sign-in before going out for a warm-up, will be deemed to have signed-in that car (i.e. crashes in warm-ups cannot drive a different car).

Any driver that signs-in after the line-up is started (approximately 30 minutes before the scheduled start time), will be at the back of their heat or feature.

**Line-up Procedure**

Race line-ups will be based on the car's percentage, as outlined in the Handicap Procedure. Other than opening night, the starting positions are arranged by percentage, as earned by the car number. A high average percentage will start further back than a low average.

The line-ups will be posted on a board at a designated location of the C.V.M. The driver is responsible to confirm their line-up position and to do so promptly when your race is called.

If you are unable to start a race that you have been scheduled for, please notify the handicapper as soon as possible. If you are late for line-up, you will start at the back of your race.

The Head of Tech. may rule to start a car at the back of any race if the car or driver is not up to speed, in either practice or race, as determined by the club. The Head of Tech. may also start a car at the back of any race if the car has sustained any major damage in the previous race (last week, warm-ups, heats, etc.) or if the car has had no practice since the repair has been made. The Head of Tech. may also disqualify a car from starting a race if they feel that any repairs have not been make properly and could affect safety.

On any re-scheduled (rain-dated) races, the line-up prior to the rain-out will stand, and any new/late cars will start at the back of their heats.

**Scoring and Officiating**

All scoring is done by the Track Officials. Any problems or questions refer to Scoring Protest Section CVM to use Track Starter and Officials.

Any race passed the ½ way, can be called as complete by the Track Officials. This could be for rain, major accident, lack of cars remaining, or otherwise.

**Starts and Restarts**

The lead car has choice to pick inside or outside position when double up is ordered by the Track Officials on original starts and restarts.

All cars involved in an accident must go to the rear, including car that have spun, stopped, drove in the wrong direction, struck another car or the crash barrier or drove radically off the racing surface, as determined by the Officials. This includes the original green; the race will be restarted based on the original line-up less the involved/accident cars.

Any cars jumping (starting/moving position prior to the waving of the green flag), on the original green or any re-starts, will be penalized during or at the end of the race. The driver/car may be penalized for each car passed on the next caution by the Track Officials.

**Race Policies**

The regular number of laps per race, unless otherwise specified:

Heats	10 laps	Consi.	10 laps
Main feature	30 laps	Double features (x2)	25 laps

Anyone going out in warm-ups, other than a registered driver must be cleared by the Committee. You must be a member of the club and can only do so in the first set of warm-ups. It is advisable to notify the Handicapper of any driver changes (registered drivers) for warm-ups.

# CANADIAN VINTAGE MODIFIEDS

## GENERAL PROCEDURES, POINTS, RACE FORMAT AND HANDICAPPING

---

Any car causing 2 cautions (i.e. spinning on your own) may be black-flagged for that race only. Any driver who leaves their car unattended after an accident will be scored in last place for that race. When a large number of cars are involved, the cars will be stopped to clean-up and re-line.

Any driver that stops to argue decisions on restart line-ups will automatically restart at the rear of the field. If you do not want to take your position, you can start at the rear of the field. If a driver refuses to take his/her spot in the re-line, they will be disqualified.

Cars that have been lapped and are not up to speed may be black flagged at the discretion of the TRACK.

If a consi race is run, the first 2 exempt/qualified cars that ask, can start at the back, run until ½ way, but cannot pass cars that are scheduled for that race. If they do not abide by this, they will not be allowed to test their cars in this manner for the remainder of the season.

### **Membership and Attendance**

Multiple drivers may accumulate points under a single car number. There is no minimum driver split. Only one registered driver per car per race event. The car will be handicapped based on the car's percentage.

All drivers must have a membership package completed for that car number to participate. Any disciplinary action/suspension against one of the drivers will be applied as an action/suspension to the car and will apply to both drivers.

For 100% attendance purposes: it will apply to the car or the driver. The car must be signed in by a registered driver and be race ready. If a driver is driving a different car for the event, they must sign in accordingly. A suspended driver/car that is not applicable.

An additional Drivers Membership to be completed at any time during the year. This would allow for any unsuspected illness or work commitments and still collect points and 100% for the car.

Any driver other than the primary driver will be placed at the rear of their first feature, similar to car entering their first event mid-season. If the driver has sufficient experience and not classified as a rookie, they may be entitled to their inverted starting position for the second feature.

### **Rookies**

Any driver that does not have sufficient past experience racing as a driver with the Canadian Vintage Modifieds will be considered as a Rookie. All rookies will be exempt from the race lineups (including random drawing, handicap, etc.) for a minimum of 3 events, including both heat and feature races, and placed at the rear for the initial lineup.

Rookie lineup may be determined based on experience, performance, etc. and ordered accordingly relative to other rookies.

Rookies may be entitled to their lineup position after 3 events at the discretion of the lineup official and the Canadian Vintage Modifieds Board of Directors. On-track performance and driver competence will be considered on a case-by-case basis. Rule-of-thumb performance metric: Rookie to be within 104% of the fastest car in practice, rounded to the nearest 0.1s (i.e. 16.25s lap = 16.3s x 1.04 = 16.95s minimum).

Rookie of the Year eligibility shall consider the rookie driver's results in the overall season points (excluding second drivers) and allow for 2 'drop' nights. Second drivers and missed race events will be considered 'drops' and additional will be considered '0'. A rookie driver will be eligible if they have raced in 3 or less Canadian Vintage Modifieds events in previous years.

In limited instances, a driver may request to be exempt from rookie consideration. The Board of Directors present at-track will vote, considering the driver's on-track performance, competence and overall resume. Any driver exempt from rookie consideration will forfeit their Rookie of the Year eligibility.

Drivers who have not competed with the Canadian Vintage Modifieds in the previous 5 seasons may be considered a rookie for line-up purposes, at the discretion of the lineup official and the Board of Directors

### **Mechanic's and Powder-Puff Races**

Participants must be members and have rookie status or have not raced in the past 10 years. Drivers under the age of 18 must have parental consent (same as drivers). Driver must be a minimum of 14 years of age.

# CANADIAN VINTAGE MODIFIEDS

## GENERAL PROCEDURES, POINTS, RACE FORMAT AND HANDICAPPING

---

### 2. Points

Points and percentage earned go to the car number, not the Driver. If there is a difference in the two numbers, when you sign-in, put car number – name – driver number. Do not change the number on the side of the car (too confusing for scorers).

The points distribution for all races are listed in their respective table.

#### **Show Points:**

Show points are 30 points per night, per driver. Car must be race ready, with a registered driver, and must at least attempt warm-ups. Car must be signed in.

#### **Heat Race Points:**

10 points will be awarded for the heat race winner. 9 points will be awarded to the second-place finisher. This will continue for all cars in the heat race, to 5 points for 6<sup>th</sup> position and all remaining cars.

#### **Main Feature Points:**

30 points will be awarded for the heat race winner. 29 points will be awarded to the second-place finisher. This will continue for all cars in the main race, to 7 points for 24<sup>th</sup> position.

If more than 24 cars start the main feature, 25<sup>th</sup> etc. will be awarded 7 points, and handicapped as 24.

If events only have a single main feature (no heat races or qualifying), 10 points will be added to each position outlined above. 40 points will be awarded for the feature race winner. 39 points will be awarded to the second-place finisher. This will continue for all cars in the main race, to 17 points for 24<sup>th</sup> position.

#### **Double Feature Events:**

For events where double feature races are completed, points will be awarded based on the combined handicap points awarded based on the results of each race. Please refer to the Handicap Points Distribution:

40 points will be awarded to the car with the highest combined handicap points for the night. 39 points will be awarded to the car with the second highest combined handicap points for the night. This will continue for all cars who started at least one feature race.

#### **Qualifying Points:**

For events where qualifying is used to determine the starting order for the feature rather than heat races.

10 points will be awarded for the fastest qualifier. 9 points will be awarded to the second fastest qualifier. This will continue for all cars, to 5 points for 6<sup>th</sup> position and all remaining cars.

#### **Consi. Points:**

Are only awarded if there are more than 24 cars ready to start the feature. Consi. points will be awarded to cars that start and finish the consi. but do not qualify for the feature. The finish 1 and points of 4 are awarded to the first non-qualifier for the feature. You cannot receive consi. points and feature points in the same night.

#### **Rainout Show Points:**

Rainout show points will be awarded to the drivers that have signed-in and have attempted to line-up for the heats. All drivers must participate in at least one warm-up session per event, or go to the back of their respective heat. At the discretion of the Tech. Committee, a driver can be exempted from this, due to mechanical problems, but they must report to the Head of Tech. to be excused. Driver's meetings are mandatory, and attendance will be taken. A member associated with the car may represent the driver, or the driver can designate a Committee Member to represent him. The penalty for missing the meeting will be loss of protest rights for that event, and the car will start at the back of his/her heat.

#### **Rainout policy:**

This will depend on how far into the program the races are. From the time the heats are lined-up (i.e. 6:30), show points will be awarded. This will be the only points awarded unless the consi. has run. If the only races left to run are the feature(s), points will be awarded as such: show points, consi points (if applicable), and the qualified cars that are race ready, for the main feature will receive 15 points. This is only if partial purse is to be paid out; the awarded finish of tow money will be used for handicapping all cars that night.

# CANADIAN VINTAGE MODIFIEDS

## GENERAL PROCEDURES, POINTS, RACE FORMAT AND HANDICAPPING

---

### Points Distribution

<b>Show Points</b>	30
--------------------	----

<b>Heat Races/Qualifying</b>	
1	10
2	9
3	8
4	7
5	6
To finish...	5
DNF	5
Finish	Points

<b>Consi Race</b>	
Finish	Points
1	4
2	3
3	2
To finish...	1
DNF	0

<b>Main Feature</b>	
Finish	Points
1	30
2	29
3	28
4	27
5	26
6	25
7	24
8	23
9	22
10	21
11	20
12	19
13	18
14	17
15	16
16	15
17	14
18	13
19	12
20	11
21	10
22	9
23	8
24	7

# CANADIAN VINTAGE MODIFIEDS

## GENERAL PROCEDURES, POINTS, RACE FORMAT AND HANDICAPPING

---

### 3. Race Format and Handicapping

#### Race Format

##### **Race Format (19 or less Cars):**

2 - 25 lap Features

##### **Race Format (20 or more Cars):**

3 – 10 lap Heat Races

Consolation Race (if required)

30 lap Feature.

The race format is at the discretion of the track officials, with input and recommendations provided by the C.V.M. board of directors. The following conditions are subject to change as required.

Any driver requesting scratch position will be lined-up at the back of their respective heat or feature (double feature), for that race only, unless otherwise requested. If you are a late arrival, you will be lined-up at the back of your heat, this will be your position all night. If you have missed your heat, you cannot run at the back of any other heat, you will automatically go to the consi.

If a qualified car requests scratch in the feature they will start at the back of the field, behind the consi cars.

#### Handicapping for First Event

For the 1<sup>st</sup> race event of the season, drivers will either draw for positions for the heat races or qualify for their starting position for the main feature (at the discretion of the track).

#### **Double Feature Lineup:**

Events with less than 20 cars will run double feature races.

The first feature will be lined-up based on the results of the drivers' draw or qualifying. The result from the first feature will determine the line-up for the second feature.

All lead lap cars will be inverted based on the official results of the first feature (i.e. last car on lead lap starts 1<sup>st</sup>). The remainder of the lineup will be determined based on the official results of the first feature. Any cars disqualified from the first feature for minor infractions may be allowed to start at the rear, at the discretion of the Tech. Director.

#### **Heat race Lineup:**

Events with 20+ cars, heats are divided equally among the cars signed in at the appointed time, into a maximum of 3 heats.

The number of cars per heat race may be adjusted equally less, depending on the car numbers present, or the feature size (24 cars or less). You must finish your heat to qualify directly to the main feature. Cars that do not finish their heat will be lined up at the rear for the main feature, ahead of cars that scratch position.

Qualifying for the main feature by the heat races when there are less than 24 cars, cars will be lined up based on the finishing results of the three heats. 1<sup>st</sup> place in first heat starts first, 1<sup>st</sup> place in second heat starts second, 1<sup>st</sup> place in third heat starts third, 2<sup>nd</sup> place in first heat starts fourth, 2<sup>nd</sup> place in second heat starts fifth, 2<sup>nd</sup> place in third heat starts sixth, etc. Only the cars that are non-finishers or non-starters in either the heat or semi will be lined-up at the back of the feature.

If at the appointed sign-in time there are greater than 24 running cars, a consi race will be ran. The top 6 finishing position cars from each race will automatically transfer to the main feature. You must finish your heat to qualify directly to the main feature. The top 6 finishing position cars from the consi will transfer to the main feature, and will be lined up for the start at the rear, behind all scratch cars.

Rookies may start at the back of their heats for the first two nights; they may take their qualified spot in the feature or consi.

Drivers will be lined-up in the heat position they have drawn based on the following:

- Drivers from the previous year,
- Drivers that have driven with the club in past years,
- Drivers that have driven with the club without full driver's memberships,
- Drivers that have driven before (any division that disqualifies them as a rookie),
- Followed by the rookies at the back of the heat as they have drawn.

# CANADIAN VINTAGE MODIFIEDS

## GENERAL PROCEDURES, POINTS, RACE FORMAT AND HANDICAPPING

---

### Consi line-up:

- Non-qualifying finish order from heat and in order of heats respectfully.
- D.N.F.'s. by finish order from heat and in order of heats respectfully.
- D.N.S.s. by heat line-up and in order of heats respectfully.
- Late arrivals at the back.

### Feature line-up:

- Feature lineup will be based solely on the night's performance and finishing order from the heats and consi.

<b>19 or less Car:</b>	<b>20 or more Cars:</b>
2 - 25 lap Features	Heat 1 finishing order
Starting positions based on position drawn for the first feature. Lead lap finishers to be inverted for the second feature, followed by remaining cars.	Heat 2 finishing order
	Heat 3 finishing order.
	The remaining form the consolation race

Example (based on 20 cars):	1 <sup>st</sup>	1 <sup>st</sup> in Heat 1	2 <sup>nd</sup>	1 <sup>st</sup> in Heat 2
	3 <sup>rd</sup>	1 <sup>st</sup> in Heat 3	4 <sup>th</sup>	2 <sup>nd</sup> in Heat 1
	5 <sup>th</sup>	2 <sup>nd</sup> in Heat 2	6 <sup>th</sup>	2 <sup>nd</sup> in Heat 3
	etc.			

### Handicapping for Regular Events

For all regular events after the first event where points are awarded, the handicap points average from the previous 2 events will be used to complete the starting line-ups. Each car will be lined up based on the inverse of the car numbers 2-night season points average (i.e. lowest points average will be first, highest average will be last).

Cars that have zero points for missed races for the 2-week average sample will be assumed as 71 points and the average will be completed accordingly.

For the second and third points events, all cars will be handicapped accordingly.

i.e.	Race 1	Race 2	Average
	66 points	70 points	68 points
	0 points (71)	66 points	68.5 points

Ties for position will be determined based on the higher handicap points awarded for the previous event (missed events will be considered 0 points). Subsequent events will be used as a tie-breaker if required. If handicap points cannot determine a tie-breaker, a coin toss (or equivalent) will be used.

### **Double Feature Lineup:**

Events with less than 20 cars will run double feature races.

The first feature will be lined-up based on the results of the 2-night handicap points average. The result from the first feature will yield the line-up for the second feature.

All lead lap cars will be inverted based on the official results of the first feature (i.e. last car on lead lap starts 1<sup>st</sup>). The remainder of the lineup will be determined based on the official results of the first feature. Any cars disqualified from the first feature for minor infractions may be allowed to start at the rear, at the discretion of the Tech. Director.

### **Heat race Lineup:**

Events with 20+ cars, heats are divided equally among the cars signed in at the appointed time, into a maximum of 3 heats. 1st heat represents the lowest 2-night handicap points average and the back of the 3rd heat being the highest 2-night handicap points average.

The number of cars per heat race may be adjusted equally less, depending on the car numbers present, or the feature size (24 cars or less). You must finish your heat to qualify directly to the main feature. Cars that do not finish their heat will be lined up at the rear for the main feature, ahead of cars that scratch position.

Qualifying for the main feature by the heat races when there are less than 24 cars, cars will be lined up based on the finishing results of the first heat, followed by the finishing results of the second heat, followed by the finishing results of the third heat. Only the cars that are non-finishers or non-starters in either the heat or semi will be lined-up at the back of the feature.

# CANADIAN VINTAGE MODIFIEDS

## GENERAL PROCEDURES, POINTS, RACE FORMAT AND HANDICAPPING

If at the appointed sign-in time there are greater than 24 running cars, a consi race will be ran. The top 3 finishing position cars from the first heat, the top 6 finishing position cars from the second heat, and the top 9 finishing position cars from the third heat will automatically transfer to the main feature. You must finish your heat to qualify directly to the main feature. You must finish your heat to qualify directly to the main feature.

### Consi line-up:

- Non-qualifying finish order from heat and in order of heats respectfully.
- D.N.F.'s. by finish order from heat and in order of heats respectfully.
- D.N.S.s. by heat line-up and in order of heats respectfully.
- Late arrivals at the back.

### Feature line-up:

- Feature lineup will be based solely on the night's performance and finishing order from the heats and consi.

	<b>19 or less Car:</b>		<b>20 or more Cars:</b>
	2 - 25 lap Feature		Heat 1 finishing order
			Heat 2 finishing order
			Heat 3 finishing order.
	Starting positions based on handicap position for the first feature. Lead lap finishers to be inverted for the second feature, followed by remaining cars.		The remaining form the consolation race
Example (based on 20 cars):	1 <sup>st</sup>	1 <sup>st</sup> in Heat 1	2 <sup>nd</sup>
	3 <sup>rd</sup>	3 <sup>rd</sup> in Heat 1	4 <sup>th</sup>
			...
	7 <sup>th</sup>	1 <sup>st</sup> in Heat 2	8 <sup>th</sup>
	9 <sup>th</sup>	3 <sup>rd</sup> in Heat 2	10 <sup>th</sup>
			...
	13 <sup>th</sup>	1 <sup>st</sup> in Heat 3	14 <sup>th</sup>
	15 <sup>th</sup>	3 <sup>rd</sup> in Heat 3	16 <sup>th</sup>
			...

### Additional Procedures

Bubble cars will be used to fill the field on any race event that one feature is run. Bubble cars must take the original green in the feature. They will be selected and listed in order, from the consi finish. If they start the main feature, they will not be awarded consi points. If the first bubble car does not line-up (i.e. 4th from the consi), the next available car that has lined-up will get the chance to start the feature.

Accident cars may wish to run 1 lap in the feature. All cases will be at the discretion of the Tech. Committee. Cars allowed to run 1 lap will be scored last regardless of first lap cautions, etc. And cannot compete more than 1 lap. If we have more than 24 cars, the car that wants to run 1 lap, and has qualified for the feature, will be credited with 24th place money and points, and a bubble car will be allowed to start the feature.

# CANADIAN VINTAGE MODIFIEDS

## GENERAL PROCEDURES, POINTS, RACE FORMAT AND HANDICAPPING

### Handicap Points Distribution:

Double Feature (Per Race)	
Finish	Points
1	50
2	43
3	37
4	32
5	28
6	24
7	21
8	18
9	15
10	13
11	11
12	9
13	8
14	7
15	6
16	5
17	4
18	3
19	2
20	1

Single Feature	
Finish	Points
1	80
2	72
3	65
4	59
5	54
6	49
7	44
8	40
9	36
10	33
11	30
12	27
13	24
14	22
15	20
16	18
17	16
18	14
19	13
20	12
21	11
22	10
23	9
24	8

Qualifying	
Finish	Points
1	20
2	19
3	18
4	17
5	16
6	15
7	14
8	13
9	12
10	11
11	10
12	9
13	8
14	7
15	6
16	5
17	4
18	3
19	2
To Finish	1

Heat/Consi	
Finish	Points
1	20
2	18
3	16
4	14
5	12
6	10
7	8
8	6
9	4
To Finish	2

# CANADIAN VINTAGE MODIFIEDS

## DUTIES OF COMMITTEE AND STAFF

---

### DUTIES OF COMMITTEE AND STAFF

#### **President:**

- Voice, face and representative of the C.V.M.
- Co-ordinate the club and Committee activities towards the betterment of the C.V.M.
- To do promotional work or deal with any issues with Promoters and sponsors.
- Inform the Treasurer of expected purse (prior to each event).
- To delegate and assign projects to Committee Members as they arise
- Chair all club meetings.
- Heads up the Business Committee.
- Prepare the schedule with the Vice President, also the tentative schedule.
- Sets agenda for meetings
- Reports to the membership.
- At the November Executive Meeting the outgoing President is responsible for ensuring that the members of his/her committee provide the following to the Incoming committee;
- Copies of all track contracts covering the past season.
- Copies of letters of understanding from the previous year to all club sponsors.
- Committee procedure books.
- All financial records from the previous year(s) including all receipts, bank statements, financial reports from the Children's Christmas Party, Fund Raising Events, Picnic, Banquet, plus any other special events from the previous year.
- All correspondence from the previous year.
- All meeting minutes as well as meeting minute books.
- Club membership list with current addresses and phone numbers.
- Sponsorship list with current addresses and phone numbers.
- All government forms.
- Banquet agenda.
- All car show contacts, equipment and associated paraphernalia.
- All tech tools along with inventory list.

#### **Vice President:**

- Takes over President's job, if president is unable to continue to fulfill his duties.
- 2<sup>nd</sup> position on the Business Committee.
- Policing all Committee Members.
- Responsible for members at the track (questions, concerns from the members).
- Prepares tentative schedule with the President.
- Supports the President with sponsors.
- News, announcements, classifieds for the newsletter.
- Responsible for Staff at the track.
- Reports to the President
- Handle all protests.
- Responsible for implementing Mentor System.

#### **Treasurer:**

- Keeps all financial records.
- Presents monthly financial report.
- Responsible for insuring drivers' payouts are available by the next racing weekend, pick-up purse from promoter and distributes funds to the drivers.
- Issues cheques for club expenses.
- Responsible for outstanding accounts (tracks, sponsors, memberships, penalties, etc.).
- Works on Business Committee
- Reports at Committee and general meetings.

# CANADIAN VINTAGE MODIFIEDS

## DUTIES OF COMMITTEE AND STAFF

---

### **Secretary:**

- Keeps minutes of all meetings.
- Is responsible for mailing list (members, sponsors, track, hall of fame, etc.)
- Mails out club literature including monthly newsletter.
- Prepares and sends newsletter for printing.
- Works on Business Committee.
- Responsible for events calendar.
- Notifies promoters of contract names and Committee for passes.
- In charge of stationary.

### **Board Member #1 - Head of Tech.:**

- Runs safety and tech. from our rulebook, using tech. procedures as outlined.
- Reports to Vice President.
- Uses Board members 2-5 for jobs as needed.
- Contact for tech., for all drivers, owners, and co-ordinates with track Tech. Officials.
- Responsible for tech. tools and radios.
- Ensures decals for sponsors are given and are on all cars.

### **Board Members #2 & #3 - Social Committee:**

- Tech. support.
- Trophies and awards.
- Social functions (spring dance, picnic, Christmas party, etc.)
- 50/50 draws and raffles
- Banquet.
- Reports progress at Committee meetings for all functions.
- Fundraisers.
- Responsible for banners.

### **Board Members #4 & #5 - Web Site:**

- Tech. support.
- Web site.
- Press releases (newspaper, radio, race results).
- Car shows.
- Reports monthly to Committee.
- Driver's profiles.
- Media kits for track announcers and promoters.

### **Responsibilities and guidelines for all Committee Members:**

- Attend 100% of all meetings, Committee and general (unless excused).
- Attend 80% of all race meets and events (notification to President or Vice President of all absents).
- Responsible for updating on missed meetings.
- No conflict of interest - club comes first - you accepted the position, and are expected to do your job fairly.
- Honesty and high principles are considered essential in Committee Members.
- Phone chain set up at first Committee meeting.
- Review general meeting minutes and Committee meetings.
- Be at general meetings ½ hour early to review Committee meeting minutes.
- The above Committee job descriptions can be altered to suit each Committee, but all jobs and responsibilities must be fulfilled.
- All minutes, mailing lists (Membership, Sponsors, Tracks, Hall of Fame, etc.), records (statistics, feature line-ups and finishes etc.) stationary, financial statements, Tech. tool, radios, banners etc., notes, devices or equipment that belong to the C.V.M. is to be turned over to the next President and Vice President. The President and Vice President are to be responsible for all of the above mentioned items until handed over to the elected person(s) assuming the president and Vice President positions for the following year.

# CANADIAN VINTAGE MODIFIEDS

## DUTIES OF COMMITTEE AND STAFF

---

### **Handicapper:**

- Keep statistics on each event (races, drivers, points, etc.).
- Determine line-up (handicap); post the line-up with note of the number of cars to qualify, and line-up cars.
- Deal with drivers, in regards to line-ups, points, etc.
- List the feature finish with time of posting.
- Makes sign-in sheet available to drivers.
- Have points available by Monday night.
- Speak at driver's meeting, in regards to schedule of events, etc.
- Takes attendance at driver's meetings.
- Must be available during protest period.
- Must be there when track (pit gate) opens.
- Must keep track of cars taking warm ups.
- Must supply a copy of the official feature finish to the Treasurer.

# CANADIAN VINTAGE MODIFIEDS

## MENTOR PROGRAM

---

### MENTOR PROGRAM

The C.V.M. Mentor Program has been created to help familiarize new members with the C.V.M. The program will give encouragement to new members and provide someone to go directly to with questions regarding on-track procedures/situations. The program also gives all existing club members a Mentor to speak to, when required, about on-track incidents which might occur.

The Head Mentor will ask members to volunteer to be Mentors. Mentors must have a minimum of 5 years with the club as a driver. Mentors must make a commitment to attend 90% of the races.

All first year and rookie drivers will have a Mentor. All drivers must have a Mentor until they reach the age of 16.

All mentored drivers that ran a shared car or limited schedule in their mentored year, will retain a Mentor the following year.

A Mentor cannot be a family member of driver.

Mentors will be introduced at each drivers meeting so other drivers know who is mentoring whom.

Before a mentored driver is allowed to take his/her position in a race, the decision will be made by the Mentor or a drivers group or Race Officials. A Mentor alone will not make this decision.

All mentored cars must run a yellow stripe on their rear bumper.

The Mentor's car number or name will appear, in brackets, behind the mentored car's number on the line-up board.

There will be a mandatory meeting of mentored drivers, after each general drivers meeting, at the race track.

If a mentored driver is involved in a crash, it is mandatory that the incident be discussed with the Mentor and Club Officials (that is not associated with the car/driver), so that the mentored driver receives an unbiased opinion of the incident.

It is recommended that a mentored driver report any altercation that has occurred during a race, to their Mentor.

This is a basic outline to get this program started. More things will be added as ways to make this system work better and offer the most encouragement to new members.





**CANADIAN VINTAGE MODIFIEDS**  
**TECHNICAL BULLETIN**

---

**CANADIAN VINTAGE MODIFIEDS**  
**2026 TECHNICAL BULLETIN**

Bulletin No.: (i.e. 2026-01)		Issued Date:	
Rule Number:			
Rule:			
Issue:			
Clarification:			

A technical bulletin may be a modification or clarification to an existing rule in the published rule book for that calendar year. The technical bulletin is to be presented to the board of directors and signed off by the Technical Director and President (or Vice-President) prior to the bulletin being published. A technical bulletin supersedes any previous iteration of an existing rule. All technical bulletins shall be brought to the attention of the membership and shall be made publicly available. The board of directions for the next racing season may choose to revise the rule book to include the technical bulletin and revised rule.

**CANADIAN VINTAGE MODIFIEDS**  
**TECHNICAL BULLETIN**

---

**CANADIAN VINTAGE MODIFIEDS**  
**2026 TECHNICAL BULLETIN SIGN-OFF**

Revision Log

<u>Bulletin Number</u>	<u>Rule Number</u>	<u>Issued Date</u>	<u>Tech Sign-Off</u>	<u>President Sign-Off</u>
Bulletin 2026-01				
Bulletin 2026-02				
Bulletin 2026-03				
Bulletin 2026-04				
Bulletin 2026-05				
Bulletin 2026-06				
Bulletin 2026-07				
Bulletin 2026-08				
Bulletin 2026-09				
Bulletin 2026-10				